

PRATIKO LIGHT

PRATIKO LIGHT

**Strutture mobili che organizzano lo spazio.
Postazioni di lavoro singole che trovano un
piacevole punto d'incontro.**

*Movable structures to organize space.
Individual workstations that create a
pleasant meeting point.*









Creare ordine e trasmettere innovazione: è il risultato della perfetta armonia dei piani di lavoro abbinati alle paretine.

Order creation and innovation: it is the result of the perfect harmony of the work tops combined with partitions.



policarbonato *polycarbonate*



tessuto e policarbonato *fabric and polycarbonate*



dimensioni pareti *partition dimensions*

PRATIKO LIGHT

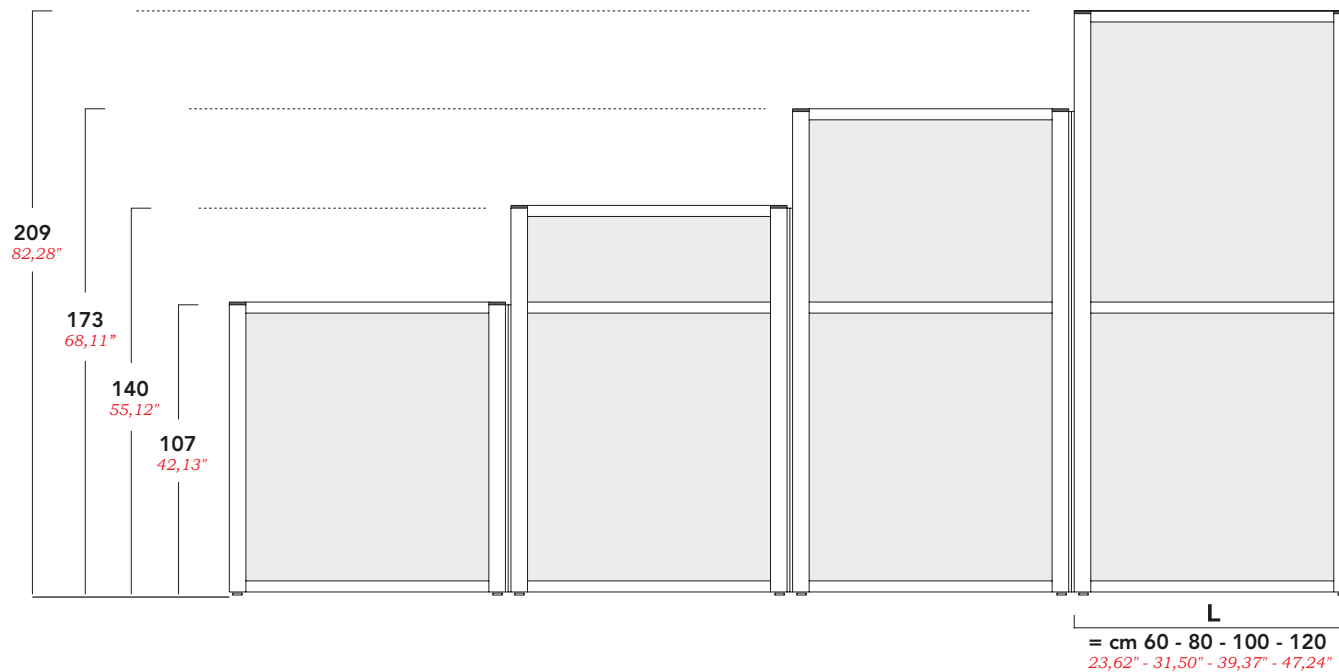

NOVITÀ NEW

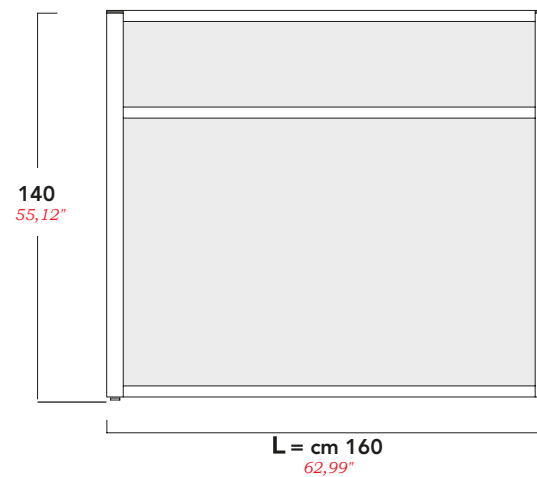

PRATIKO LIGHT GOAL

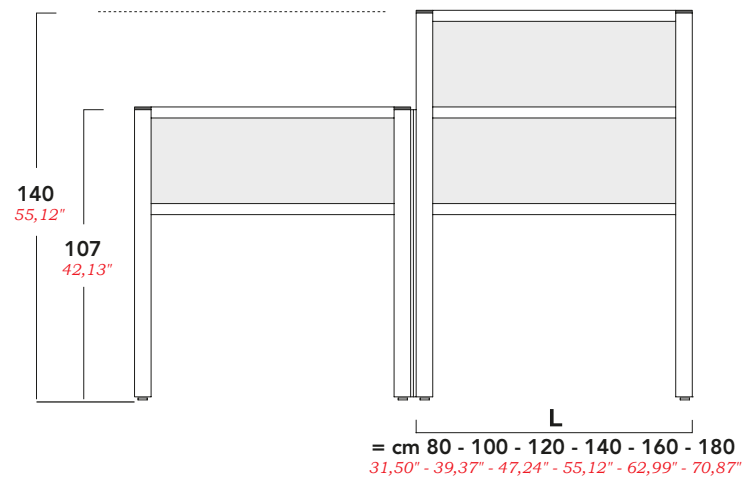

cartella colori *colours card*

melaminici *melamine*

MBI
bianco
white



MGR
grigio
grey



MNO1
noce
walnut



trasparenti *transparent*

VTR
vetro trasparente
transparent glass



POL
policarbonato
polycarbonate



tessuti *fabrics*

T001
rosso
red



T005
azzurro
light blue



T007
grigio scuro
dark grey



T010
nero
black



accessori *accessories*

profilo di aggancio in continuo (2/3/4 vie a 90°) *connection profile (90° - 2/3/4 ways)*

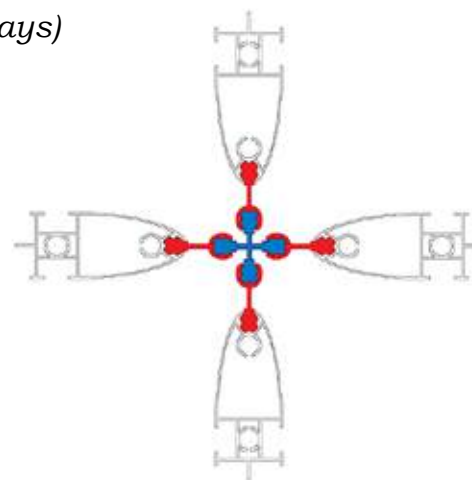
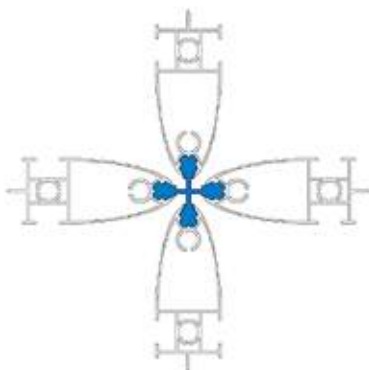
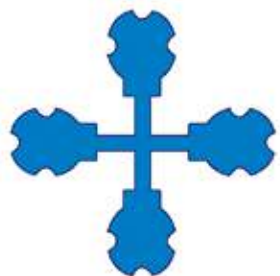

staffa con ruota *bracket with wheel*



piede stabilizzatore in ghisa *cast iron stabilizing foot*

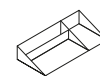
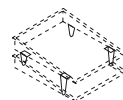
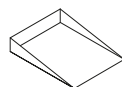
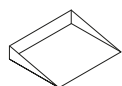

Vaschetta porta corrispondenza
Letter tray
L 35 H 27

Vaschetta porta corrispondenza
Letter tray
L 27 H 35

**Supporto-distanziatore per
vaschetta porta corrispondenza**
Support-spacer for letter tray

Vaschetta porta oggetti
Objects holder
L 35 H 15

Portapenne
Pen holder
L 8,5 H 9.5

indicazioni per assemblaggio *fitting instructions*

Esempi / *Examples*

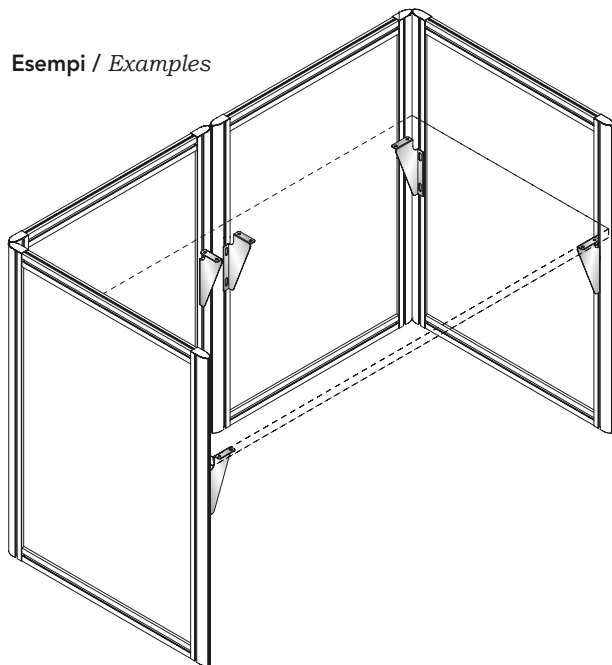

In molte situazioni "Pratiko" diventa un sistema strutturale.
Con l'ausilio delle staffe reggimensole e del piede boomerang può infatti reggere un piano di lavoro.

*Pratiko can be well used as a complete structure.
By the help of the boomerang leg and shelf brackets it can even support a desktop.*

1

Soluzione con piede boomerang e staffe: per una assoluta libertà di movimento

Solution with boomerang leg and brackets for a total freedom of movement

2

Soluzione con piede singolo e staffe: per stabilità e sostegno perfetti

Solution with single leg and brackets for perfect stability and support

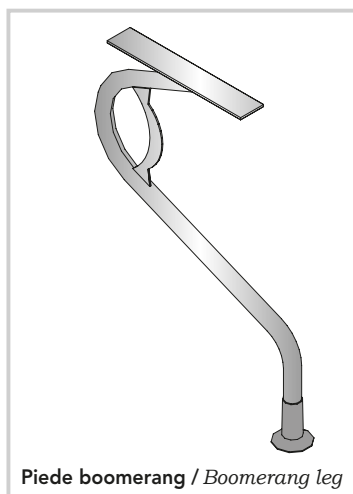

Piede boomerang / *Boomerang leg*

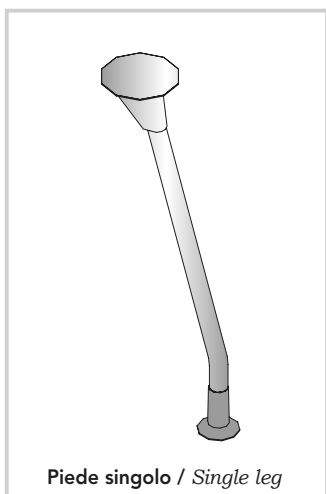

Piede singolo / *Single leg*

Staffa reggipiano / *Top bracket*

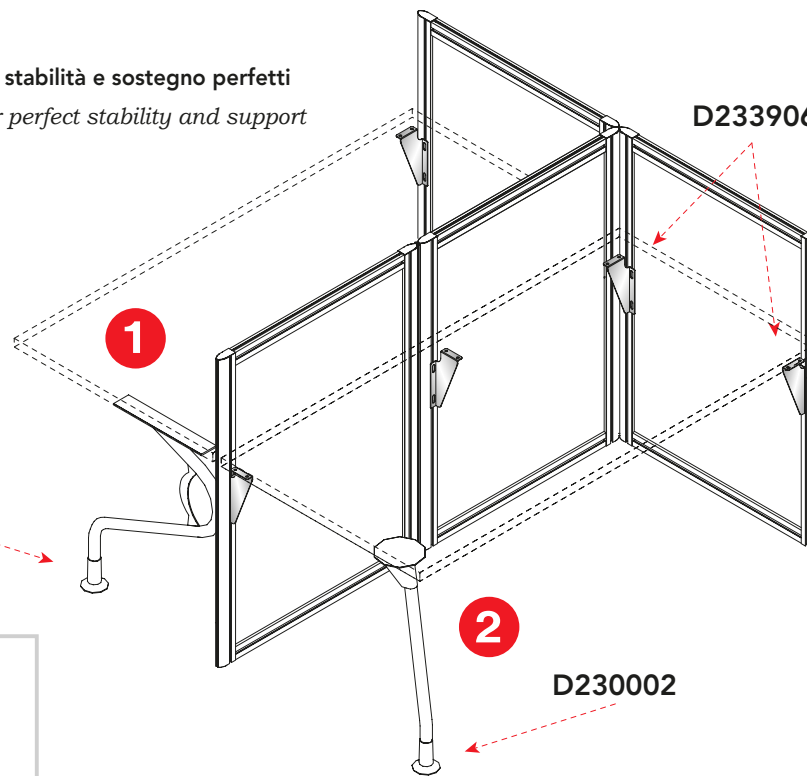
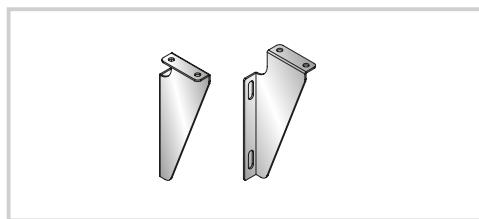

D232014

D233906

D230002

soluzione per scrivania LEGODESK o similari *solution for LEGODESK desk or similar*

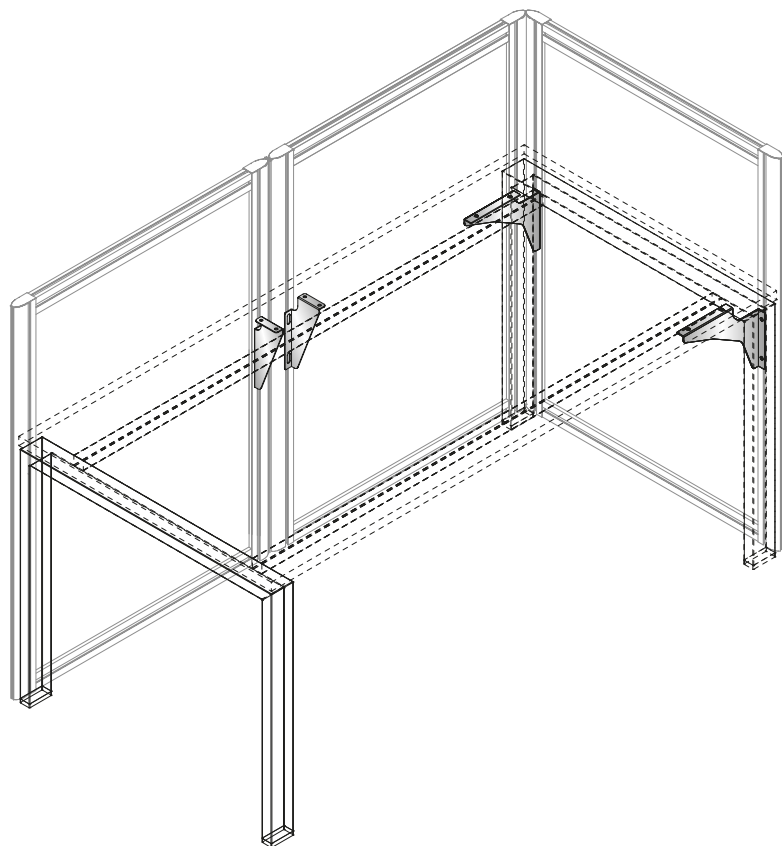

NOVITÀ NEW

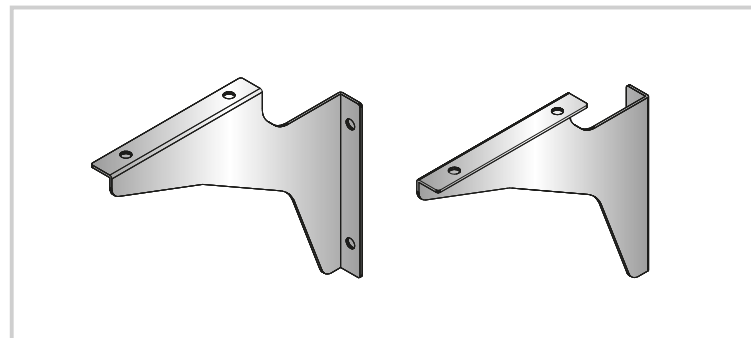

soluzione universale per tutte le altre scrivanie *universal solution for all other desks*

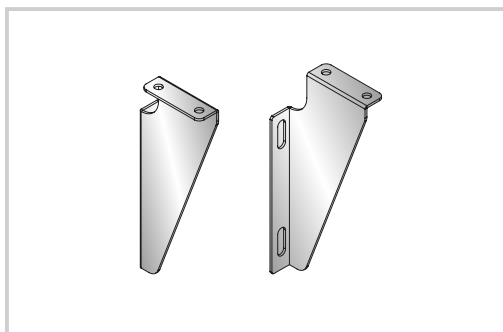

indicazioni per assemblaggio *fitting instructions*

N.B. Ogni parete è dotata "di serie" di profilo di aggancio in parallelo, 2,3 e 4 vie a 90° e di profilo di aggiustaggio.
Non necessita di ulteriori giunzioni.

N.B. Each partition is supplied with 90° 2/3/4 ways parallel connection profile and adjustment profile.
No additional connection elements are necessary.

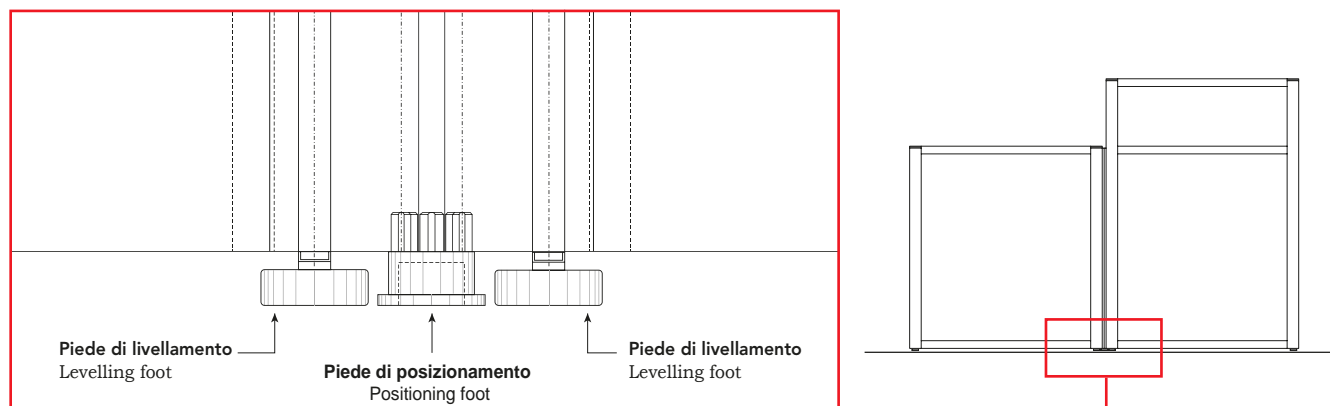
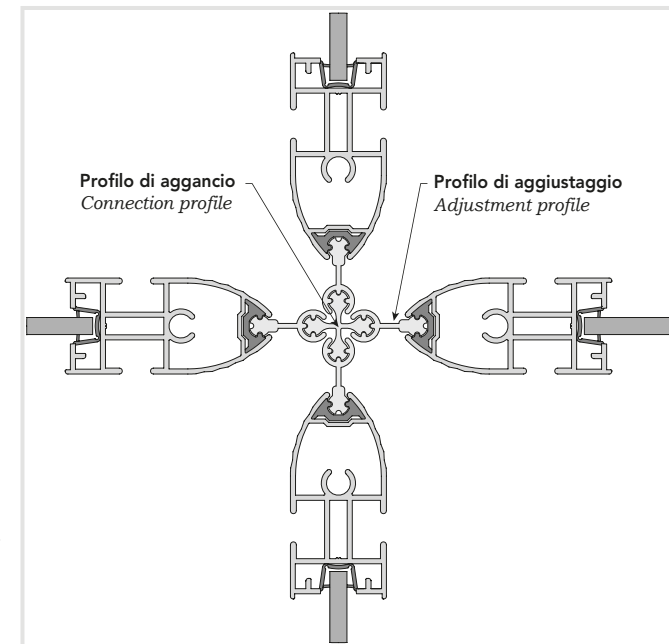
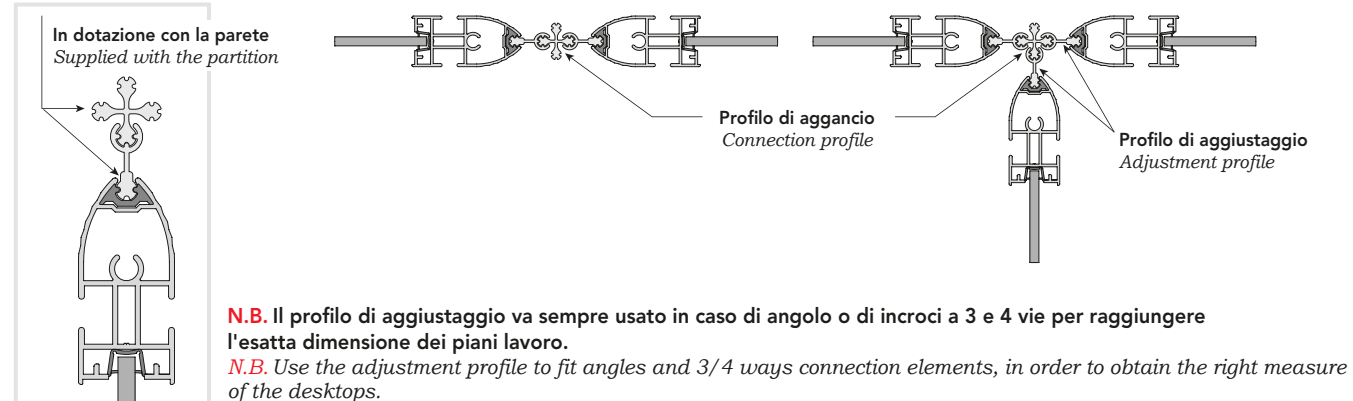

indicazioni per assemblaggio *fitting instructions*

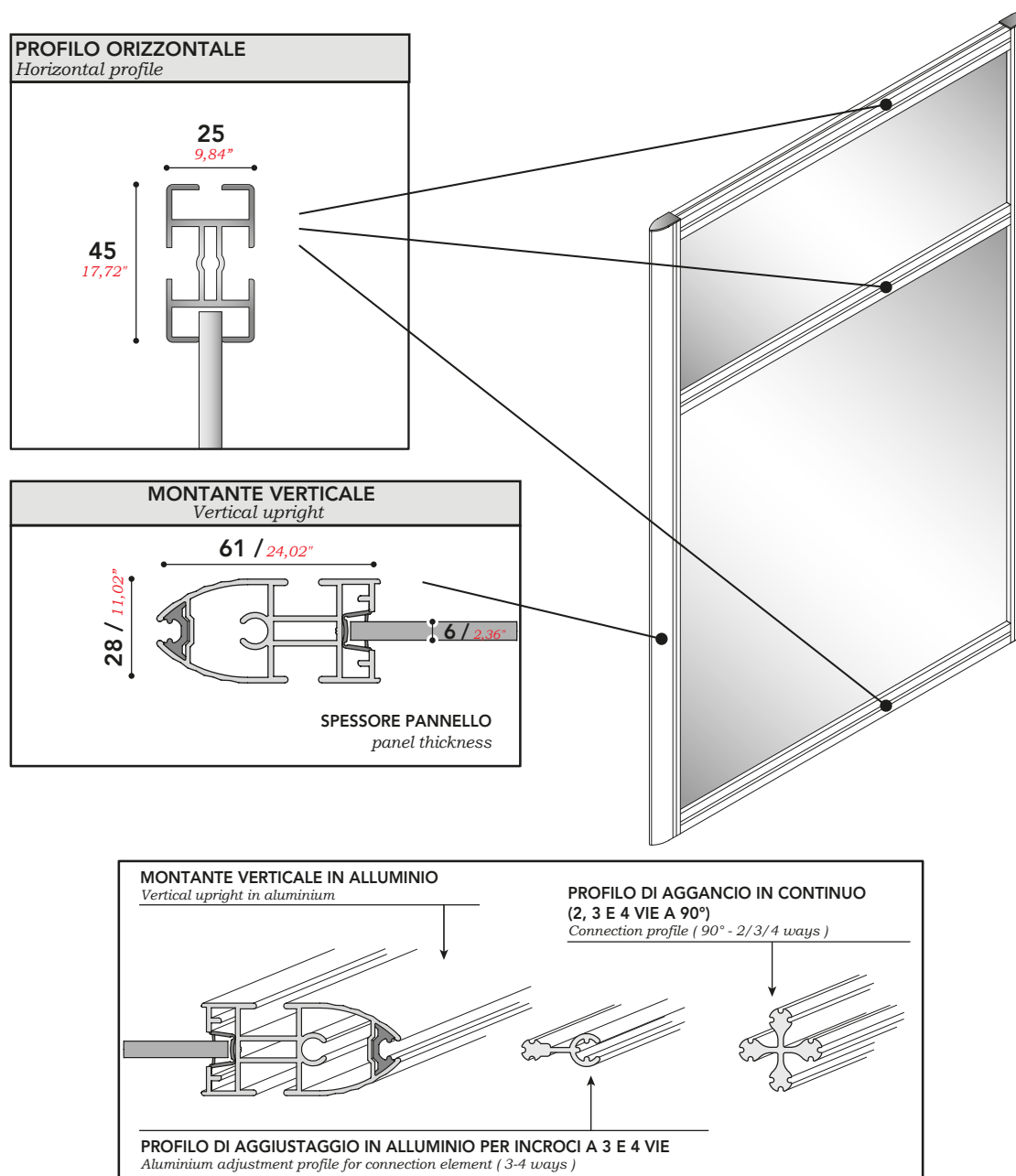

indicazioni per assemblaggio *fitting instructions*

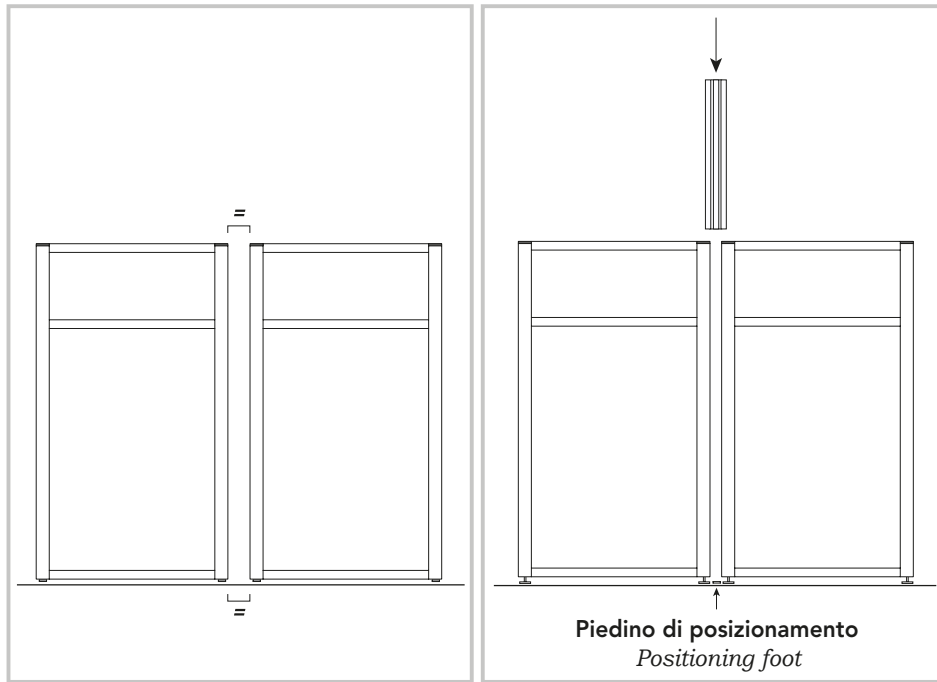

- 1) Agendo sui piedini verticali, verificare che le pareti siano regolate alla stessa altezza e che siano perfettamente parallele.
- 2) Se necessario va inserito il profilo di aggiustaggio.
- 3) Inserire il piedino di posizionamento
- 4) Inserire il profilo di aggancio

- 1) *By the help of the levelling feet, adjust the two partitions on the same height and perfectly parallel.*
- 2) *If necessary fit the adjustment profile.*
- 3) *Insert the positioning foot*
- 4) *Insert the connection profile*

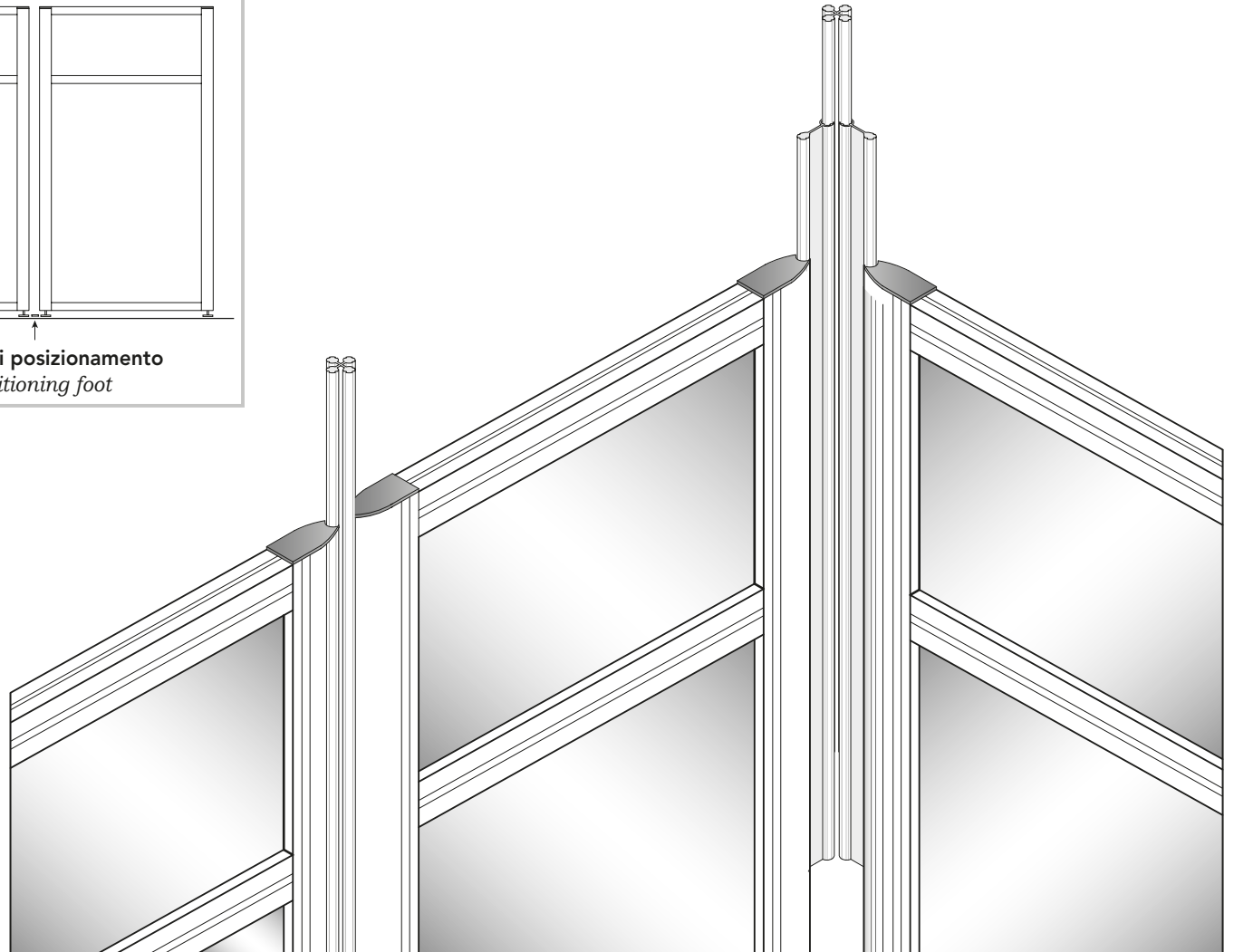

RENDERING, FOTORITOCÇO E IMPAGINAZIONE:

C Lab Pesaro di Matteo Candelaresi

DELLA ROVERE OFFICE & CONTRACT Srl

*Via Mengaroni, 22 - 61025 Montelabbate (PU) - Italy - tel. +39 (0721) 90 891 - fax +39 (0721) 90 89 20
dellarovere@dellarovere.it - www.dellarovere.it*