

**how  
we  
meet  
your  
needs**

*"The details are not the details.  
They make the design."*

*Charles Eames*



2

3



Da oltre cinquant'anni Leyform unisce tradizione, artigianalità ed esperienza per fornire un prodotto di alta qualità, che rispetta i più severi standard italiani ed internazionali. Grazie al perfetto connubio di questi elementi siamo sempre in grado di soddisfare ogni esigenza del cliente, offrendo il prodotto migliore per ogni tipo di impiego.

For over fifty years Leyform combines tradition, craftsmanship and experience to deliver a high quality product that meets the highest Italian and international standards. Thanks to the perfect combination of these elements, we are always able to meet all customer needs, offering the perfect product for every environment.

Pour plus de cinquante ans Leyform allie tradition, savoir-faire et l'expérience pour fournir un produit de haute qualité qui répond aux normes italiennes et internationales les plus élevées grâce à la combinaison parfaite de ces éléments, nous sommes toujours en mesure de répondre à tous les besoins des clients, en offrant le produit idéal pour tous les environnements. afin de vous fournir toute l'énergie et productivité dont vous avez besoin.

Seit über fünfzig Jahren vereint Leyform Tradition, Handwerkskunst und Erfahrung, um ein qualitativ hochwertiges Produkt zu liefern, welches den strengsten italienischen und internationalen Standards entspricht. Dank der perfekten Kombination dieser Elemente, sind wir immer in der Lage, alle Kundenwünsche zu erfüllen, und das perfekte Produkt für jede Umgebung zu bieten.

# qualità | *quality | qualité | qualität*



La progettazione accurata delle sedute Leyform tiene conto dell'ergonomia e delle tendenze del design così da soddisfare le esigenze di arredo e al tempo stesso di comfort, sia professionale che domestico. Il nostro pensiero, le azioni, i comportamenti ed i prodotti sono l'espressione di precise scelte progettuali e qualitative.

Ergonomics & Design. Our Goal is continuing to develop products to fulfill the real and professional needs of all clients. Our thoughts, actions, behaviors and our products are the result of specific design choices and quality.

Ergonomie et nouvelles tendances du design sont toujours considérées pour satisfaire les exigences de nos clients. Nos idées, gestes et produits sont l'expression de nos choix concernant les projets et la qualité.

Die sorgfältige Planung des Produkts berücksichtigt die Ergonomie und Designrends, um die konkreten Bedürfnisse des Benutzers zu erfüllen. Unsere Ideen, Handlungen, Verhaltensweisen und Produkte sind der Ausdruck präziser Entscheidungen hinsichtlich Planung und Qualität.





Grazie alla costante attenzione e alla perseveranza nella ricerca Leyform da tempo ha intrapreso la strada dell'ecosostenibilità, credendo fortemente in questa risorsa per poter presentare un prodotto al passo con i tempi, e garantire al cliente un acquisto che sarà facilmente smaltibile al termine del suo ciclo di vita. L'azienda è certificata per la qualità a norma ISO 9001 e per l'ambiente a norma ISO 14001.

Research and innovation for the planning of eco-sustainable solutions to guarantee a product up with the times and easily disposable at the end of his life cycle. Certification to ISO 9001 and ISO 14001 standard is a guarantee of our quality standard.

Leyform parcourt une route eco-soutenable à travers la recherche attentive et persévérante afin de vous présenter un produit contemporain et qui sera aussi simple à éliminer dès qu'il aura terminé sa vie. Notre usine est certifiée ISO 9001 et ISO 14001.

Leyform legt großen Wert auf die Forschung und setzt sich seit Langem für die Umweltfreundlichkeit ein, denn diese Ressource ist von großer Wichtigkeit, um aktuelle Produkte anzubieten und für die Kunden ein Produkt garantieren zu können, welches am Ende seiner Lebensdauer leicht entsorgt werden kann. Unsere Produktionstätigkeit ist hinsichtlich Qualität und Umweltschutz nach ISO 9001 bzw. ISO 14001 zertifiziert.

## attesa | *visitor / visiteur / Besuchersessel*



## operative | *operational / opérateur / Drehstühle*



## direzionali | *executive / direction / Chefsessel*

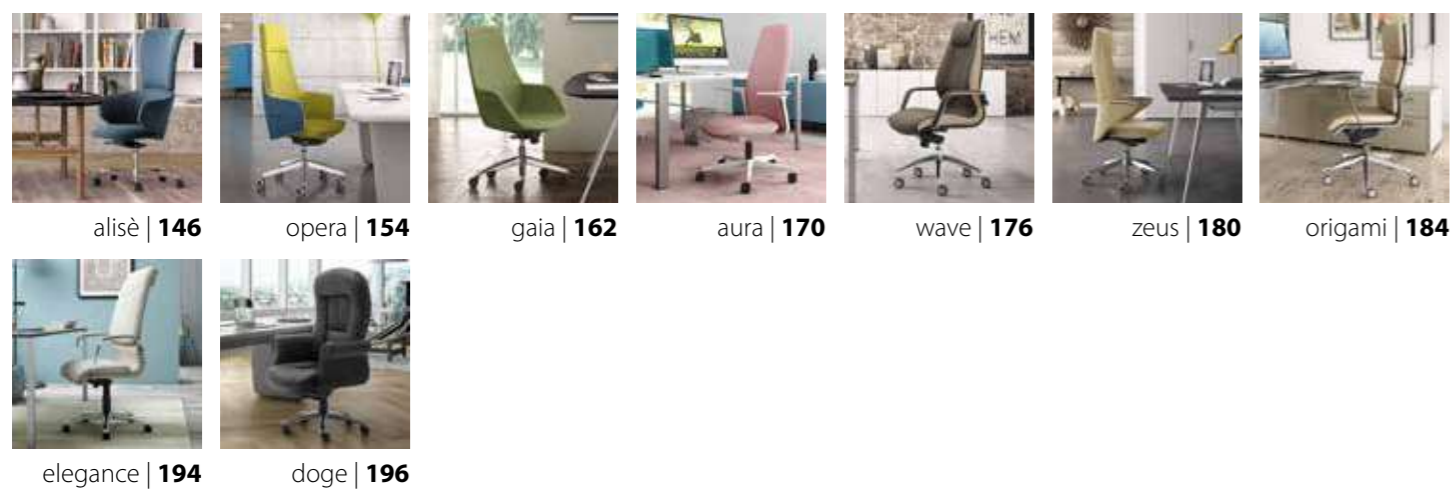

## sgabelli | *stools / tabourets / Barhocker*

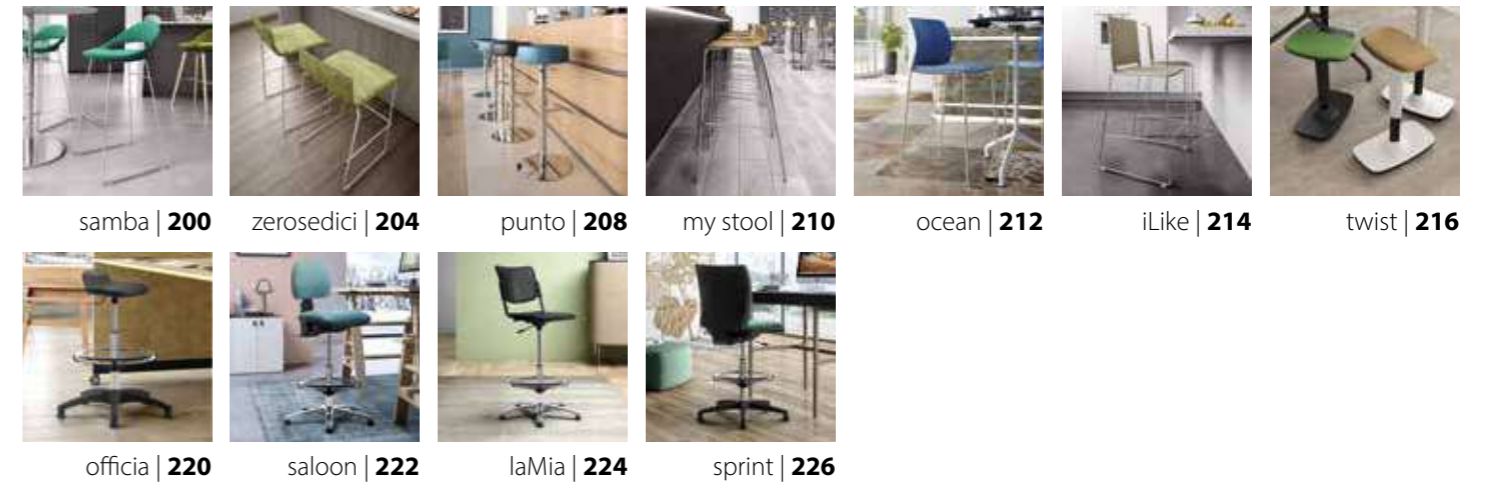

## collettività | *public / collectivité / Mehrzweckstühle*

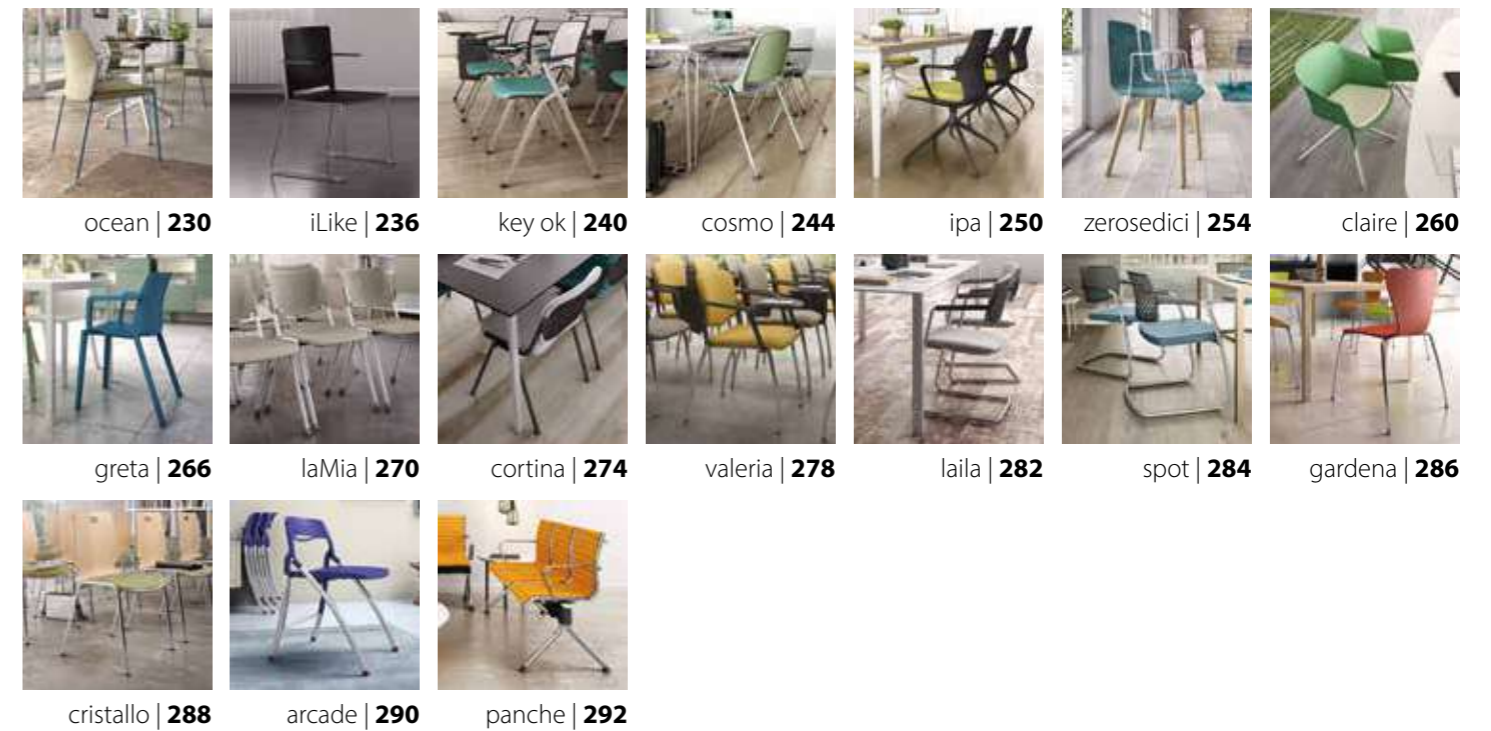

## tavoli | *tables / tables / Tische*



# attesa | *Leyform*



noà | 14



ola | 22



lia | 30



gogo | 36



vic | 42



around | 44



liv | 56



kos | 62



lizzy | 66



samba | 70



victoria | 76



reef | 84



viviana | 90



clac | 92

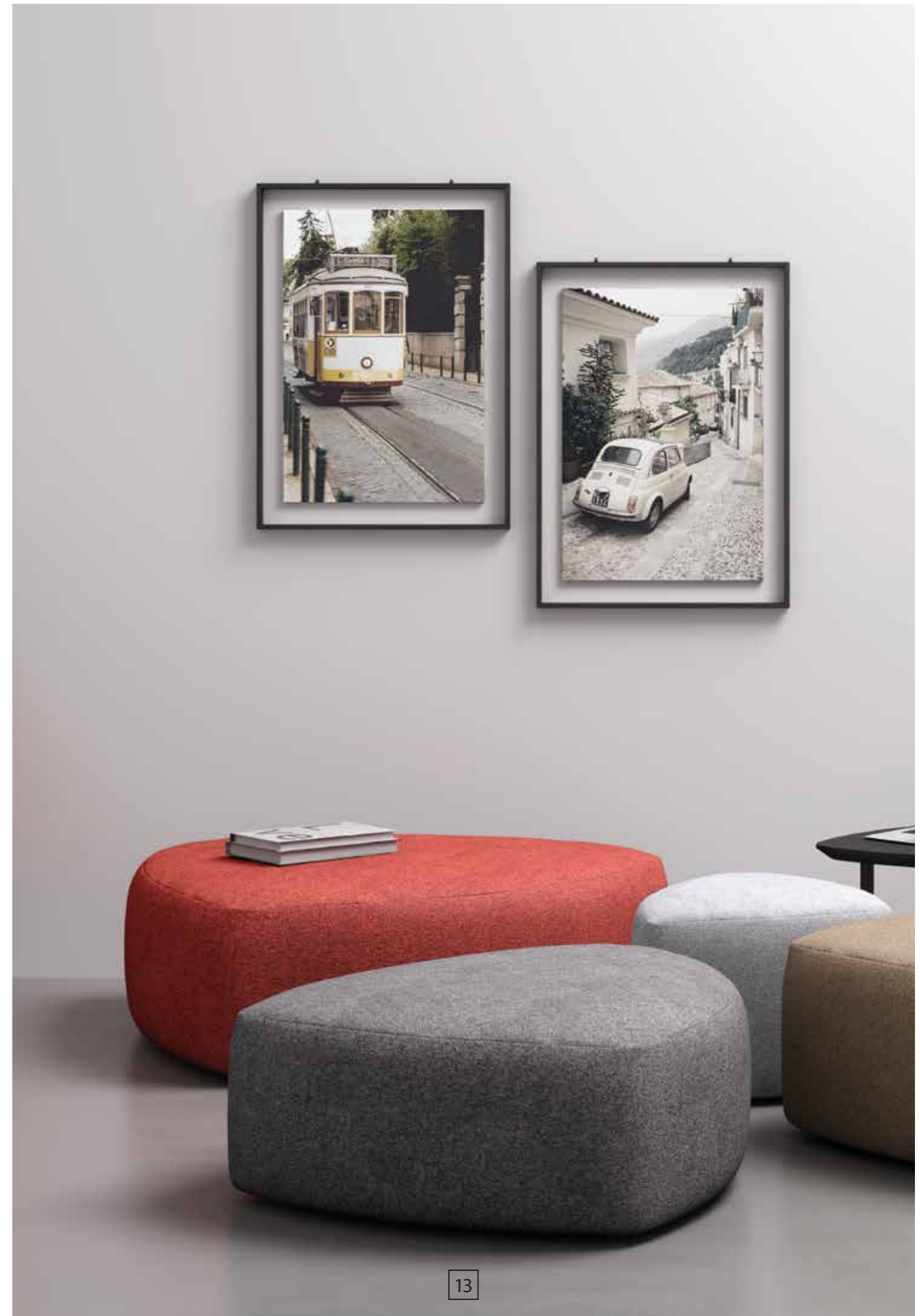



## noà | *Nicola Cacco*



Chiamarlo divano sarebbe riduttivo. Noà propone elementi di diverse lunghezze per creare composizioni sempre nuove. Il suo sistema modulare permette la creazione di spazi dal sapore unico, mescolando con sapienza i suoi volumi. I tavolini completano l'esperienza d'uso, senza però complicarne le forme o lo stile.

Calling it a sofa would be an understatement. Noà offers elements of different lengths to create ever-changing compositions. Its modular system allows the creation of unique spaces by skillfully mixing its volumes. The tables complete the user experience without complicating its forms or style.

L'appeler canapé serait réducteur. Noà propose des éléments de différentes longueurs pour créer des compositions toujours nouvelles. Son système modulaire permet de créer des espaces avec un goût unique, en mélangeant habilement les volumes. De petites tables complètent l'expérience de l'utilisateur, sans en compliquer la forme ou le style.

Es als Sofa zu bezeichnen, wäre zu kurz gegriffen. Noà bietet Elemente in verschiedenen Längen, um immer neue Kompositionen zu schaffen. Das modulare System ermöglicht die Kreation von Räumen mit einer einzigartigem Flair und einer geschickten Mischung seiner Volumen. Kleine Tische vervollständigen die Erfahrung des Benutzers, ohne seine Form oder seinen Stil zu komplizieren.







Rivestimento in tessuto, piano tavolo in legno nobilitato  
 Fabric upholstery, table top in melamine  
 Revêtement en tissu, plateau de table en bois mélaminé  
 Stoffbezug, Tischplatte melaminharzbeschichtet





Dettaglio seduta, rivestimento in tessuto  
 Seat detail, fabric upholstery  
 Détail de l'assise, revêtement en tissu  
 Sesseldetail, Stoffbezug



**SCHIENALE "L"**

L-shaped backrest / dossier à "L" / Eckrückenlehne



**SCHIENALE SOTTILE**

slim backrest / dossier mince / schmale Rückenlehne



**SCHIENALE LARGO**

deep backrest / dossier large / breite Rückenlehne



**SEDUTA**

seat / assise / Sitz



**TAVOLI**

tables / tables / Tische

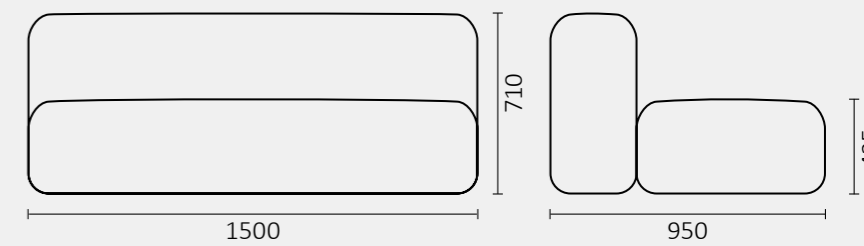

## ola | *Nicola Cacco*



Una vera e propria onda capace di percorrere gli spazi aperti. Ola trova il suo impiego in ambienti dalla diversa destinazione d'uso, dall'ufficio alla casa al settore pubblico. Il suo design funziona nel progettare ampie aree attese, grazie alla scalabilità dei suoi componenti.

A true wave capable of traveling through open spaces. Ola finds its application in environments with different purposes, from offices to homes to public spaces. Its design is perfect for designing spacious waiting areas, thanks to the scalability of its components.

Une véritable vague capable de se déplacer dans les espaces ouverts. Ola trouve sa place dans des environnements aux usages variés, du bureau à la maison en passant par le secteur public. Sa conception permet d'aménager de grands espaces d'attente, grâce à la variabilité de ses composants.

Eine echte Welle, die sich durch offene Räume bewegen kann. Ola wird in verschiedenen Umgebungen eingesetzt, vom Büro über die Wohnung bis hin zum öffentlichen Bereich. Dank der Vielfältigkeit seiner Komponenten ist er für die Gestaltung großer Wartebereiche geeignet.







Seduta imbottita e rivestita, Dettaglio seduta  
Padded and upholstered seat, Seat detail  
Assise rembourrée et tapissée, Détail du siège  
Gepolsterter Sitz, Sitzdetail



Rivestimento in tessuto, telaio in acciaio verniciato nero  
Fabric upholstery, black painted steel frame  
Revêtement en tissu, structure en acier peint noir  
Stoffpolsterung, Gestell aus schwarz lackiertem Stahl

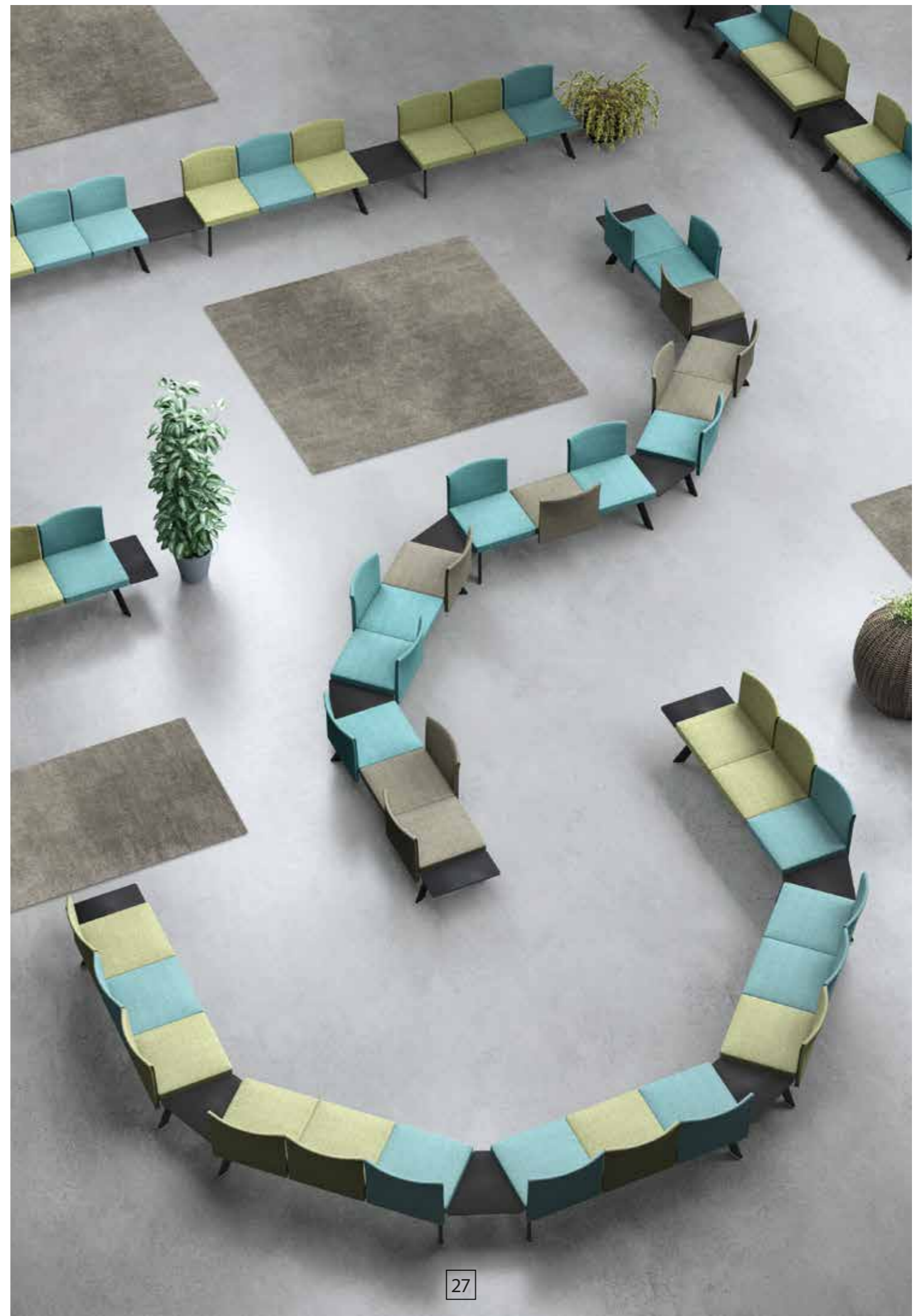



Rivestimento in tessuto, telaio in acciaio verniciato nero  
 Fabric upholstery, black painted steel frame  
 Revêtement en tissu, structure en acier peint noir  
 Stoffpolsterung, Gestell aus schwarz lackiertem Stahl



28



**SEDUTA**  
 seat / assise / Sitz



**TAVOLI**  
 tables / tables / Tische

**ELETRIFICAZIONE**  
 electrification / électrification / Elektrifizierung

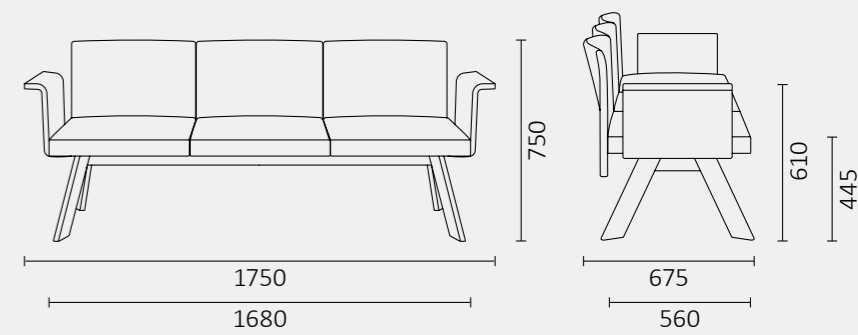

29



**lia** | *Nicola Cacco*



Poltrona o divano a due e tre posti. Un elemento dalle forme arrotondate che si fa notare per ergonomia e design. Lia contrappone le linee morbide dei suoi cuscini allo stile razionale e squadrato del telaio sottostante. Il tavolino laterale personalizza e completa l'esperienza di utilizzo, regalando un ulteriore impiego del suo bracciolo.

Armchair or two- and three-seater sofa. An element with rounded shapes that stands out for its ergonomics and design. Lia contrasts the soft lines of its cushions with the rational and square style of the frame. The side table personalizes and completes the user experience, offering an additional use of its armrest.

Fauteuil ou canapé à deux ou trois places. Un élément aux formes arrondies qui se distingue par son ergonomie et son design. Lia contraste les lignes douces de ses coussins avec le style rationnel et rectangulaire de son châssis. La table latérale personnalise et complète l'expérience de l'utilisateur, en offrant une utilisation complémentaire à son accoudoir.

Sessel oder zwei- und dreisitzer Sofa. Ein Element mit abgerundeten Formen, das sich durch seine Ergonomie und sein Design auszeichnet. Lia kontrastiert die weichen Linien der Kissen mit dem rationalen, quadratischen Stil des Untergestells. Der Beistelltisch vervollständigt das Benutzererlebnis und ermöglicht eine zusätzliche Nutzung der Armlehne.







**SEDUTA**  
seat / assise / Sitz



**TAVOLINO**  
table top / plateau table / Tischplatte



**ELETRIFICAZIONE**  
electrification / électrification / Elektrifizierung



Seduta imbottita e rivestita, telaio in acciaio verniciato nero  
Padded and upholstered seat, black painted steel frame  
Assise rembourrée et tapissée, structure en acier peint noir  
Gepolsterter Sitz, Gestell aus schwarz lackiertem Stahl

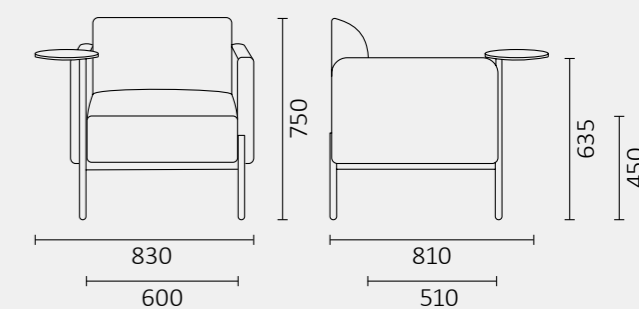
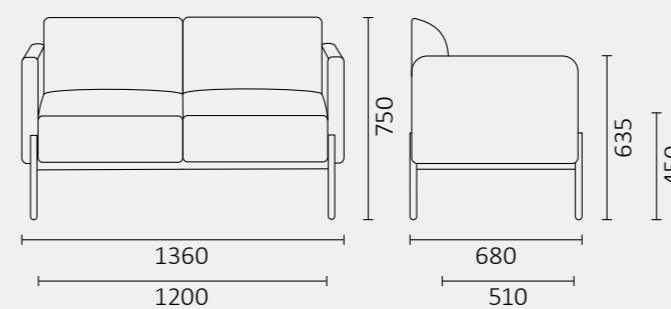

## gogo | Nicola Cacco



Due altezze e tre larghezze disponibili per un totale di 4 diverse configurazioni. Gogo ben si presta a giocare con i colori per caratterizzare diverse composizioni. Da veloce seduta a un comodo poggiatesta, fino a diventare un pratico portariviste o un semplice piano di appoggio. Cosa chiedere di più?

Two heights and three widths are available for a total of 4 different configurations. Gogo is ideal for playing with colours to create different compositions. From a simple seat to a comfortable footrest, to a practical magazine holder or a supporting structure. What more could you ask for?

Deux hauteurs et trois largeurs sont disponibles pour un total de 4 configurations différentes. Gogo se prête bien au jeu des couleurs pour caractériser différentes compositions. D'un siège rapide à un repose-pieds confortable, en passant par un porte-revues pratique ou un simple plateau de table. Que demander de plus?

Zwei Höhen und drei Breiten stehen für insgesamt 4 verschiedene Konfigurationen zur Verfügung. Gogo eignet sich gut für das Spiel mit Farben, um verschiedene Kompositionen zu charakterisieren. Vom schnellen Sitz über eine bequeme Fußstütze bis hin zum praktischen Zeitschriftenständer oder einer einfachen Tischplatte. Was kann man sich mehr wünschen?







Seduta imbottita e rivestita, rivestimento in lana  
Padded and upholstered seat, wool upholstery  
Assise rembourrée et tapissée, revêtement en laine  
Gepolsterter Sitz, Stoffbezug aus Wolle

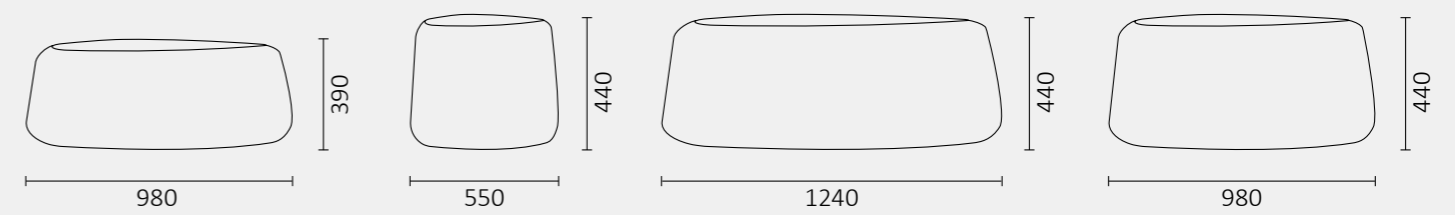

**vic** | *Nicola Cacco*



Appoggio, seduta, poggia-piedi, supporto per elementi decorativi. Molte voci per descrivere Vic, un elemento trasversale che può essere utilizzato come vero passepartout in ogni stanza. Accostalo ai tuoi complementi d'arredo, progettando lo spazio con stile e colore.

Support, seat, footrest, stand for decorative elements. Many terms to describe Vic, a versatile element that can be used as a true passe-partout in any room. Pair it with your furnishings, designing the space with style and color.

Support, siège, repose-pieds, support d'éléments décoratifs. Beaucoup de mots pour décrire Vic, un élément transversal qui peut être utilisé comme un véritable passe-partout dans n'importe quelle pièce. Combinez-le avec vos accessoires d'ameublement, en aménageant l'espace avec style et couleur.

Hocker, Sitz, Fußstütze, Unterstützung für dekorative Elemente. Viele Begriffe, um Vic zu beschreiben, ein transversales Element, das als echtes Passepartout in jedem Raum verwendet werden kann. Kombinieren Sie es mit Ihren Einrichtungsaccessoires und gestalten Sie den Raum mit Stil und Farbe.

Seduta imbottita e rivestita, Rivestimento in lana bicolore  
 Padded and upholstered seat, Wool upholstery two-tone  
 Assise rembourrée et tapissée, Revêtement en laine bicolore  
 Gepolsterter Sitz (minuscolo), Stoffbezug aus Wolle zweifarbig

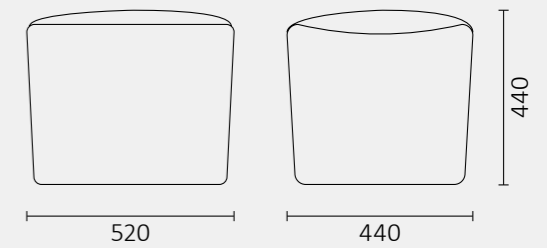
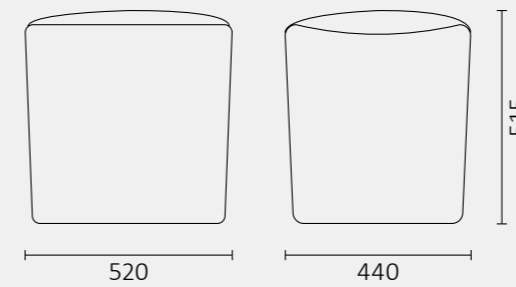

## around | Nicola Cacco



Partendo da semplici linee e forme nasce un nuovo elemento scultoreo ma sottile al tempo stesso. La splendida unione di eleganza e comodità. Around è il divano completo e adattabile a differenti situazioni, facilmente componibile ed estendibile in lunghezza per soddisfare ogni esigenza di utilizzo.

Around, minimal design and confort for this sofa searching for new lines as a modern sculpture. The perfect union of elegance and confort. Adaptable to different situations, it is the great solution in any space thanks to its modular system.

Élégance et confort. Ligne essentielle pour un élément minimal et sculptural en même temps. Le voilà Around, le canapé modulaire à votre gout. Ce siège est le trait d'union entre élégance et commodité, adaptable aux différents emplois.

Ausgehend von einfachen Linien und Formen entsteht ein neues, gleichzeitig aber schlankes plastisches Element. Die wunderbare Vereinigung von Eleganz und Komfort. Around ist ein komplettes und an unterschiedliche Situationen anpassbares Sofa, das leicht kombiniert und verlängert werden kann, um allen Benutzungsanforderungen gerecht zu werden.





Rivestimento in lana, telaio in acciaio verniciato nero  
Wool upholstery, black painted steel frame  
Revêtement en laine, structure en acier peint noir  
Stoffbezug aus Wolle, Gestell aus schwarz lackiertem Stahl





piano del tavolo con ricarica wireless, telaio in acciaio verniciato nero  
 table top with wireless charging, black painted steel frame  
 plateau de table avec chargement sans fil, structure en acier peint noir  
 Tischplatte mit kabelloser Aufladung, Gestell aus schwarz lackiertem Stahl





Piano tavolo in legno nobilitato  
 Table top in melamine  
 Plateau de table en bois mélaminé  
 Tischplatte melaminharzbeschichtet



Rivestimento in lana, piano  
tavolo in legno laminato  
Wool upholstery, table top in laminate  
Revêtement en laine, plateau  
de table en bois mélaminé  
Stoffbezug aus Wolle, Tischplatte  
melaminharzbeschichtet

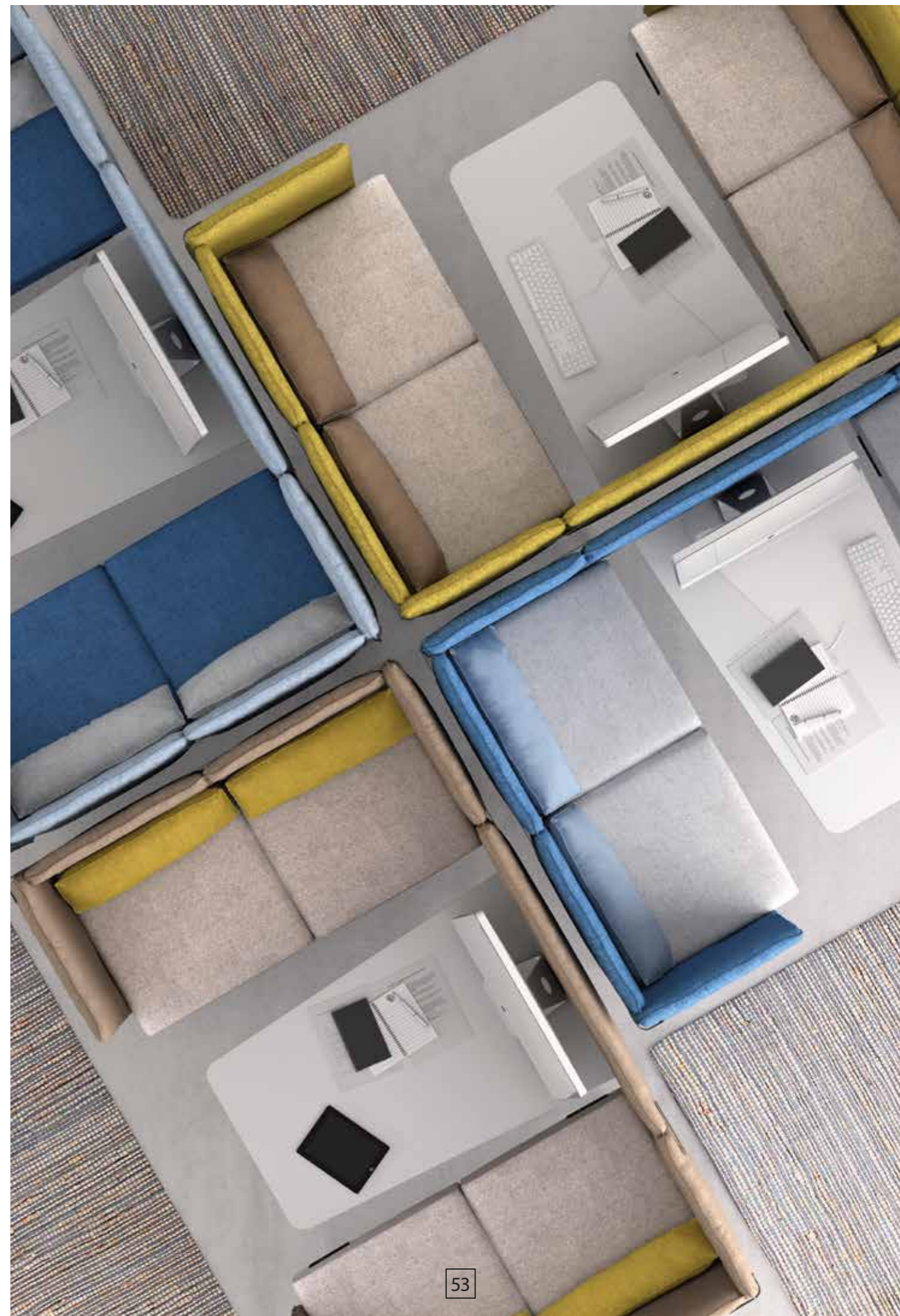

52

53

**SEDUTA**  
seat / assise / Sitz



**SEDUTA**  
seat / assise / Sitz



**FIANCHI E SCHIENALI**  
sides and backs / côtés et dos / Seiten- und Rückenpaneelen



**FIANCHI E SCHIENALI**  
sides and backs / côtés et dos / Seiten- und Rückenpaneelen



**PANCA**  
bench / banc / Bank



**AROUND LAB**



**ELETRIFICAZIONE**  
electrification / électrification / Elektrifizierung



**FINITURE**  
finishes / finitions / Gestellausführung

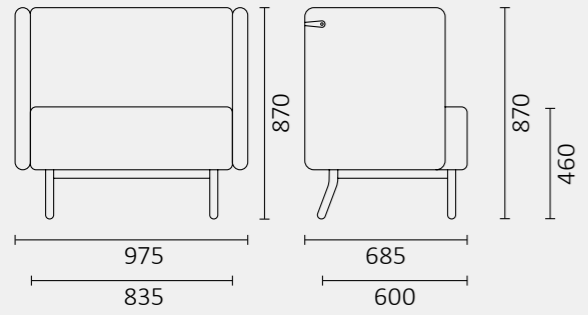

54

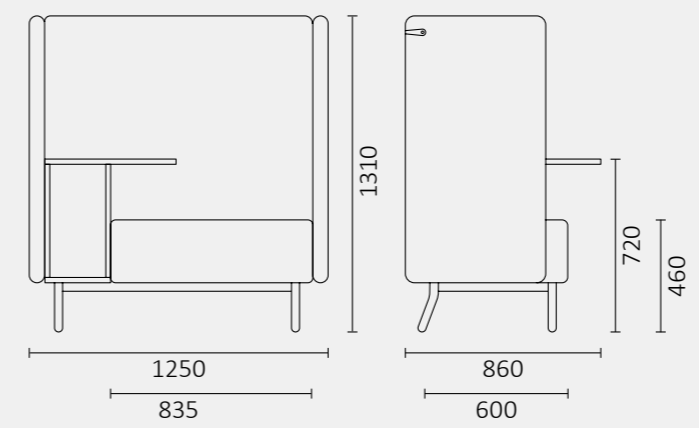
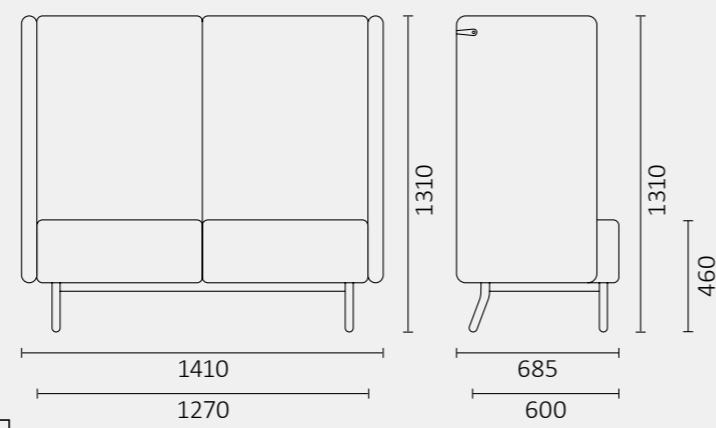

55

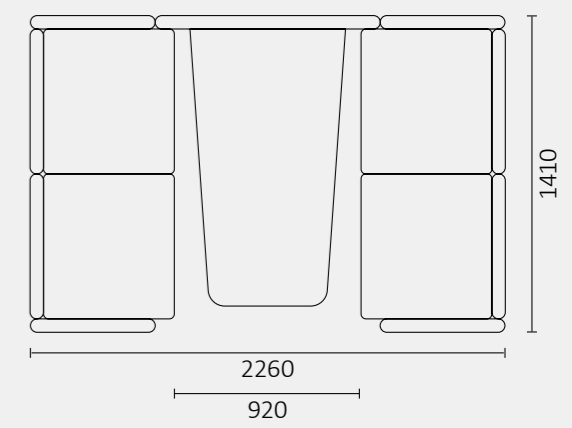

**liv** | *Nicola Cacco*



Un design sorprendente che regala un tocco di vivacità in salsa vintage. Facile da usare per personalizzare con stile piccoli o grandi aree attese. Sorprendentemente comodo grazie al comfort regalato da sedile, schienale e bracciolo, Liv è disponibile in versione poltrona o divanetto a due posti.

A surprising design with a vibrant touch in a vintage sauce. Easy to use, to customize small or large waiting areas in style. Surprisingly comfortable thanks to the padded seat, backrest and armrest, Liv is available as an armchair or two-seater sofa.

Un design surprenant avec une touche de vivacité à la sauce vintage. Facile à utiliser, il permet de personnaliser avec style les espaces d'attente, petits ou grands. Étonnamment confortable grâce au confort de l'assise, du dossier et de l'accoudoir, Liv est disponible en tant que fauteuil ou canapé deux places.

Ein überraschendes Design mit einem Hauch von Lebendigkeit in Vintage. Einfach zu verwenden, um kleine oder große Wartebereiche stilvoll zu gestalten. Liv ist dank des Komforts von Sitz, Rückenlehne und Armlehne erstaunlich bequem und als Sessel oder Zweisitzer-Sofa erhältlich.







Rivestimento in lana, dettaglio schienale  
 Wool upholstery, backrest detail  
 Revêtement en laine, détail du dossier  
 Stoffbezug aus Wolle, Detail der Rückenlehne

**SCOCCA**

shell / coque / Schale



**BASAMENTI**

bases / piétements / Fussgestelle

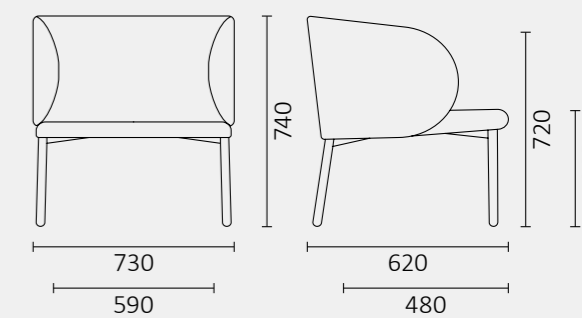
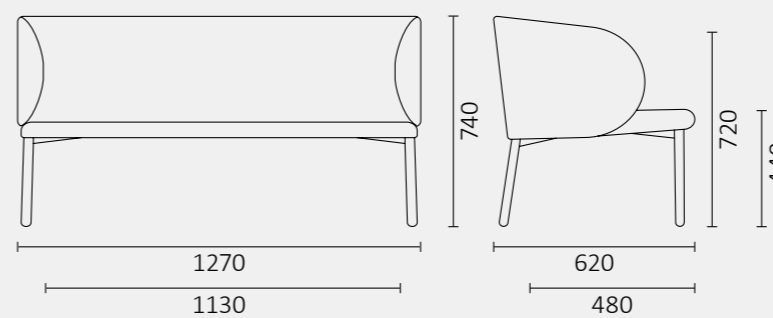



## kos | *Nicola Cacco*



Con il suo bracciolo reclinato Kos ci invita a scoprire la sua comodità. Le sue forme rigide lo accomunano ad un elemento monumentale, mentre il basamento sottile quasi scompare quando viene accostato alla struttura imbottita, regalando una forma quasi eterea. Sospesa nello spazio e nel tempo.

Kos, a suspended cradle. Robust, comfortable, enveloping, this monumental element features a light structure and a contemporary padded seat which invites to discover its remarkable comfort.

Perdu dans le temps et l'espace. Kos, un fauteuil incroyable, solide comme un monument mais aussi léger et presque suspendu dans l'espace grâce à sa base presque invisible, avec ses accoudoirs inclinés il vous invite à découvrir son confort.

Mit seinen geneigten Armlehnen lädt uns Kos ein, seinen Komfort zu entdecken. Die steifen Formen machen es zu einem monumentalen Element, während das schlanke Fußgestell fast verschwindet, wenn es mit der gepolsterten Struktur kombiniert wird und eine fast schon ätherische Form schenkt - durch Raum und Zeit schwebend.





64

Rivestimento in ecopelle, telaio in acciaio cromato  
 Eco-leather upholstery, chromed steel frame  
 Revêtement en simili cuir, structure en acier chromé  
 Kunstlederbezug, Gestell aus verchromtem Stahl

**SCOCCA**  
 shell / coque / Schale



**ELETRIFICAZIONE**  
 electrification / électrification / Elektrifizierung

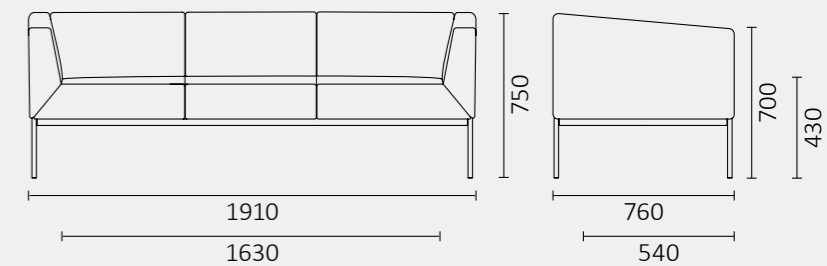
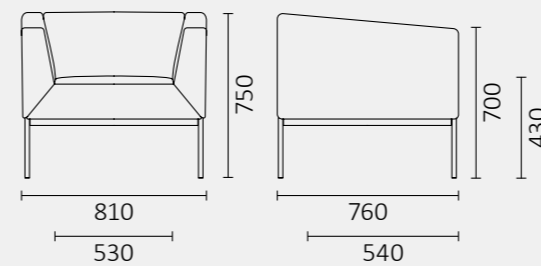

65

## **lizzy** | *Ximo Roca*



Dotata di una seduta estremamente ampia e avvolgente, Lizzy è in grado di accogliere e di far sentire subito a proprio agio. Il sedile e lo schienale trapuntato conferiscono un aspetto premium, mentre il poggiatesta è utile per trasformare una stressante giornata lavorativa in una piacevole serata di relax.

Equipped with an extremely wide and enveloping seat, Lizzy will make you feel at home. The quilted seat and back give an outstanding look to it, while the footrest helps to switch from a stressful day to a pleasant and relaxing evening.

Equipée d'un assise extrêmement large et enveloppant, Lizzy est en mesure de vous accueillir et de vous mettre immédiatement à l'aise. L'assise et le dossier matelassés donnent un aspect haut de gamme, tandis que le repose-pieds est utile pour transformer une journée de travail stressante en une agréable soirée de détente.

Ausgestattet mit einem extrem breiten und umhüllenden Sitz ist Lizzy in der Lage, den höchsten Komfort zu bieten. Der gesteppte Sitz und die Rückenlehne sorgen für einen erstklassigen Look, während die Fußstütze, einen stressigen Arbeitstag in einen angenehmen und entspannten Abend, verwandeln.





**SCOCCA**  
shell / coque / Schale



**BASE GIREVOLE**  
swivel base / base giratoire / Drehfusskreuz



**BASE SLITTA**  
sled base / piétement luge / Kufengestell



**FINITURE**  
finishes / finitions / Gestellausführung



**OPTIONAL**  
optional / option / Option



Rivestimento in lana bicolore, telaio in acciaio cromato  
Wool upholstery two-tone, chromed steel frame  
Revêtement en laine bicolore, structure en acier chromé  
Stoffbezug aus Wolle zweifarbig,  
Gestell aus verchromtem Stahl

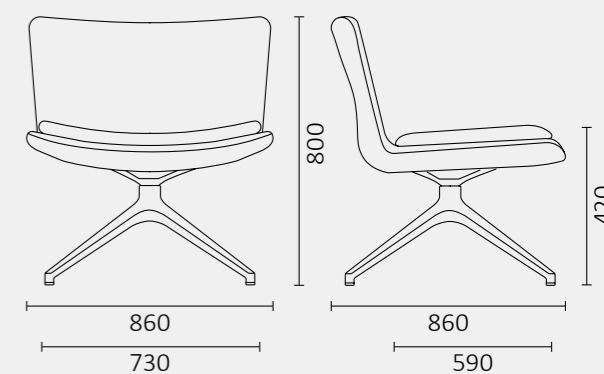
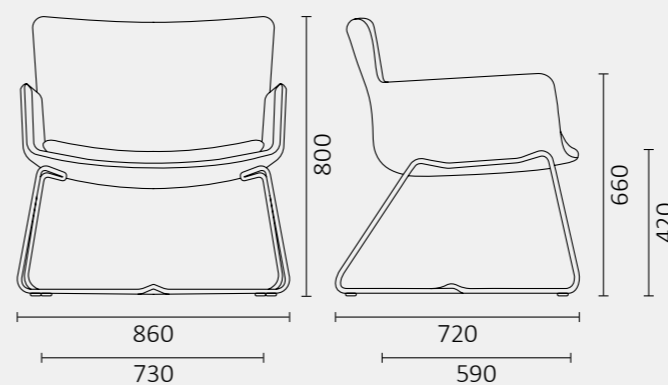

## samba | *Stefano Sandonà e Sabrina Bettini*



Pulizia nelle linee, armonia nelle curve; sono solo due dettagli di una sedia senza tempo. Samba si distingue da tutte le sedute per la sua forma accogliente e invitante. Grazie inoltre alla grande varietà di basi e rivestimenti è facilmente personalizzabile e può adattarsi ad ogni stile di vita.

Harmonious curves and minimal style, Samba: a timeless armchair with comfortable and envelopping lines. Unbelievable comfort and design, a multi-purpose product you can customize and adapt to your lifestyle. Really for all tastes.

Samba. Ligne minimale et pure mais aussi enveloppante et confortable, un refuge pour le corps et pour l'esprit où recharger ses piles. Un siège contemporain, caractérisé par des différentes options. La siège parfait pour tous.

Klare Linien, harmonische Kurven; das sind die beiden Details eines zeitlosen Stuhls. Samba unterscheidet sich von allen Sitzmöbeln durch seine gemütliche und einladende Form. Darüber hinaus ist dank der großen Vielfalt an Fußgestellen und Bezügen eine leichte Personalisierung und Anpassung an jeden Lebensstil möglich.

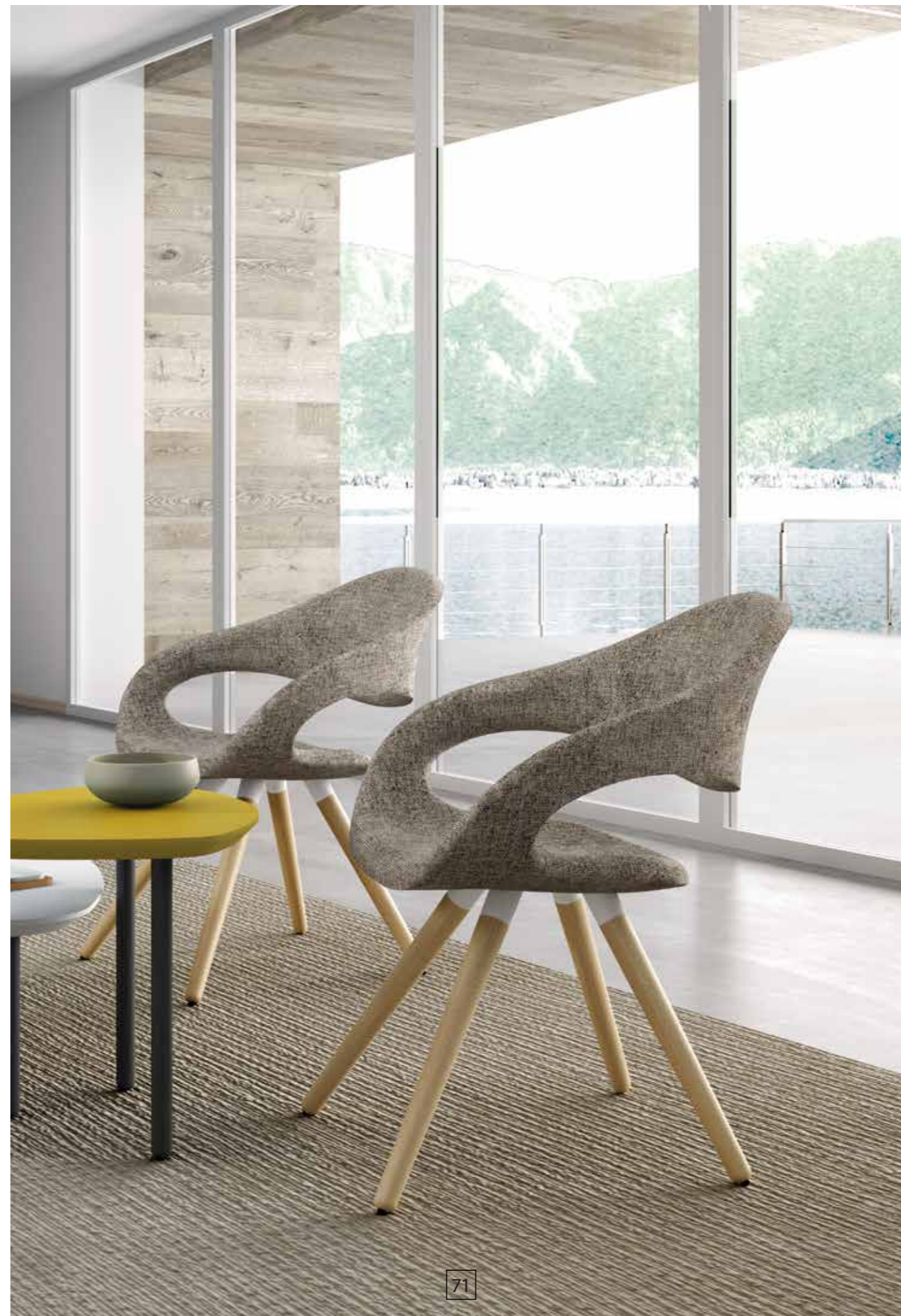





**SCHIENALE**  
backrest / dossier / Rückenlehne



**BASAMENTI**  
bases / piétements / Fussgestelle



**SGABELLI**  
stools / tabourets / Barhocker



**VERNICIATURA**  
painting / peinture / Lackierung



74

Rivestimento in lana, telaio  
in acciaio cromato  
Wool upholstery, chromed steel frame  
Revêtement en laine,  
structure en acier chromé  
Stoffbezug aus Wolle zweifarbig,  
Gestell aus verchromtem Stahl

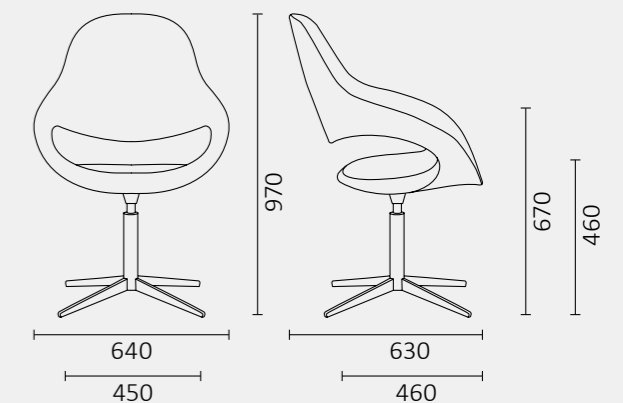
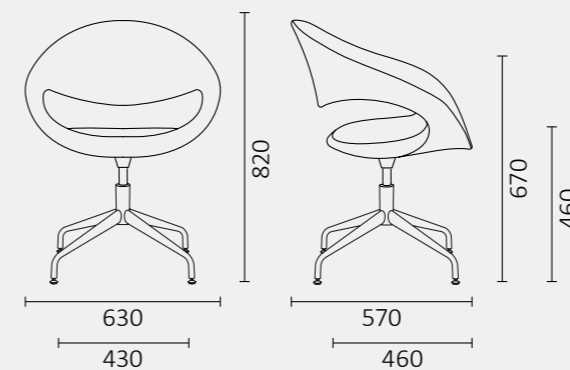

75

## victoria | *Nicola Cacco*



Come avvolto da una coperta, un piccolo rifugio per il corpo e per la mente, che circonda e crea uno spazio privato dove ricaricare le pile. Victoria dona un relax puro e un momento di pace, senza rinunciare alla straordinaria comodità e al design, caratterizzato da tre diverse altezze. Davvero per tutti i gusti.

Your very own private space to recharge yourself, a small heaven for your mind and your body. Victoria, a relax armchair coming in 3 backrest heights, perfectly suitable to the different needs.

Tout simplement: confort extrême. Refuge, cabane, privé, enveloppant endroit. Le lieu parfait pour le relax: Victoria, confort et design. Choisissez la hauteur que vous préférez pour votre relax. Vraiment pour tous les goûts.

Wie von einer Decke umhüllt, ein kleiner Rückzugsort für Körper und Geist, der einen privaten Raum schafft und umgibt, in dem die Batterien wieder aufgeladen werden können. Victoria schenkt Entspannung pur und einen Moment des Friedens, ohne auf den wunderbaren Komfort und auf das Design zu verzichten, das sich auszeichnet durch drei verschiedene Höhen. Hier bleiben keine Wünsche offen.

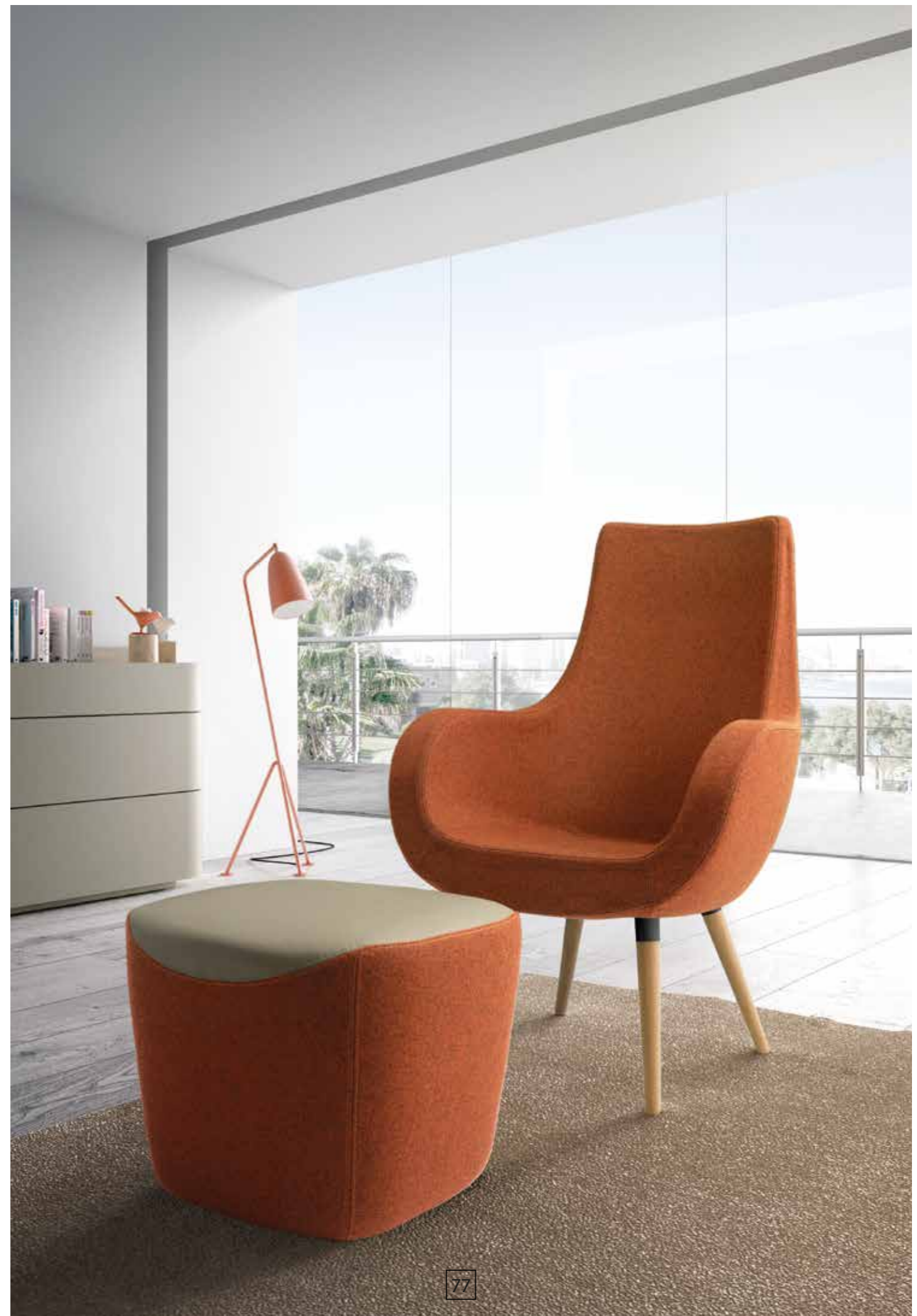







Rivestimento in ecopelle, dettaglio schienale  
 Eco-leather upholstery, backrest detail  
 Revêtement en simili cuir, détail du dossier  
 Kunstlederbezug, Detail der Rückenlehne



Rivestimento in pelle, telaio in acciaio cromato  
 Leather upholstery, chromed steel frame  
 Revêtement en cuir, structure en acier chromé  
 Lederbezug, Gestell aus verchromtem Stahl



Rivestimento in lana, dettaglio seduta  
 Wool upholstery, seat detail  
 Revêtement en laine, détail du assise  
 Stoffbezug aus Wolle, Sesseldetail

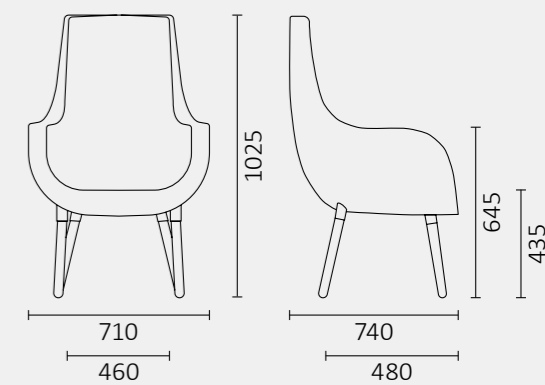
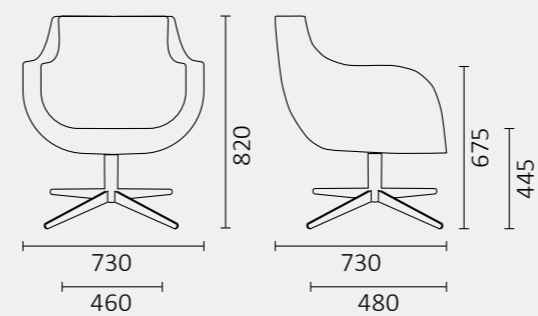

## reef | *Stefano Sandonà e Sabrina Bettini*



Reef: linee decise, modellate e tagliate di netto prima, ammorbidite e rese più dolci poi. Le sue forme rigide gli conferiscono un aspetto quasi monumentale e scultoreo, e l'intera famiglia può essere configurata a proprio piacimento con estrema semplicità. L'arte di arredare è ora alla portata di tutti.

Reef: determined lines, firstly sharp shaped, then made softer. Its firm profile features an almost sculptured and monumental look. The complete range can be custom configured with extreme simplicity. The art of decoration is finally at everyone's reach.

Reef: des lignes résolues, modelées et coupées de net en origine, et rendues souples et douces après. Ses formes fermes lui confère un aspect presque monumentale et sculptural. La collection complète peut être configuré selon le goût individuel et avec une facilité extrême. L'art de la décoration devient maintenant à la portée de tous.

Reef: determinierte Linien, zuerst scharf geschnitten, dann soft ausgearbeitet. Seine starren Formen geben ihm einen fast monumentalen und skulpturalen Look. Die ganze Familie kann nach Ihren Wünschen leicht konfiguriert werden. Die Kunst der Dekoration ist jetzt für jedermann zugänglich.





86

Rivestimento in tessuto, tavoletta laterale opzionale  
Fabric upholstery, optional side tablet  
Revêtement en tissu, tablette latérale en option  
Stoffbezug, Optionales seitliches Tablar



87



**SCOCCA**  
shell / coque / Schale



**BASAMENTI**  
bases / piétements / Fussgestelle



**ACCESSORI**  
accessories / accessoires / Zubehör



Base 4 gambe legno, rivestimento in ecopelle  
Base with 4 wooden legs, eco-leather cover  
Piètement 4 pieds en bois, revêtement en simili cuir  
4-Fussholzgestell, Kunstlederbezug

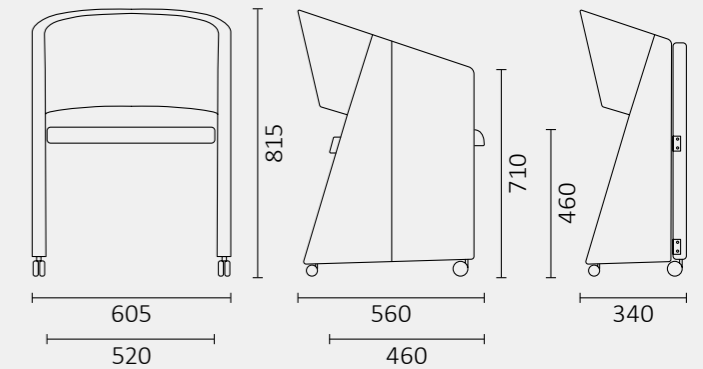
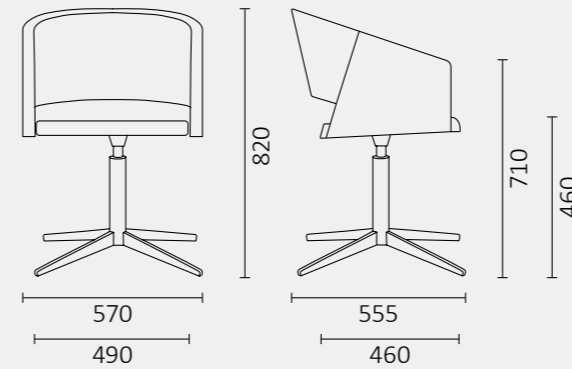

Rivestimento in tessuto, tavoletta  
laterale opzionale  
Fabric upholstery, optional side tablet  
Revêtement en tissu,  
tablette latérale en option  
Stoffbezug, Optionales seitliches Tablar

## viviana | R&d Leyform



Pensata per una sala conferenza e per ampi spazi allestiti per congressi o riunioni, Viviana è una poltroncina configurabile con e senza tavoletta, dalla seduta reclinabile, su ruote e piedini e facilmente accatastabile, una buona soluzione salvaspazio utile negli ambienti dalla doppia funzionalità.

Created for meeting rooms or conference halls, Viviana is a smart and comfortable armchair available with writing tablet and tip-up seat which allows to easy "nesting". A good space-saving solution for all multifunctional spaces.

Viviana, la chauffeuse pour les espaces congrès ou conférences, avec assise rabattable, roulettes et patins, elle est empilable horizontalement: une bonne solution pour optimiser l'espace. Vous pouvez aussi la choisir avec la tablette étroite.

Gedacht für einen Konferenzsaal und für große Kongress- oder Sitzungsräume, Viviana ist ein Sessel auf Rollen un Gleiter, der mit und ohne Schreibplatte konfiguriert werden kann, einen klappbaren Sitz besitzt und leicht gestapelt werden kann. Eine gute platzsparende Lösung, die nützlich ist in Räumen mit doppelter Funktion.

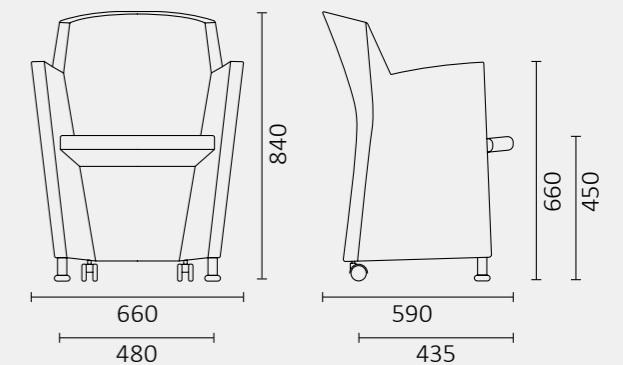
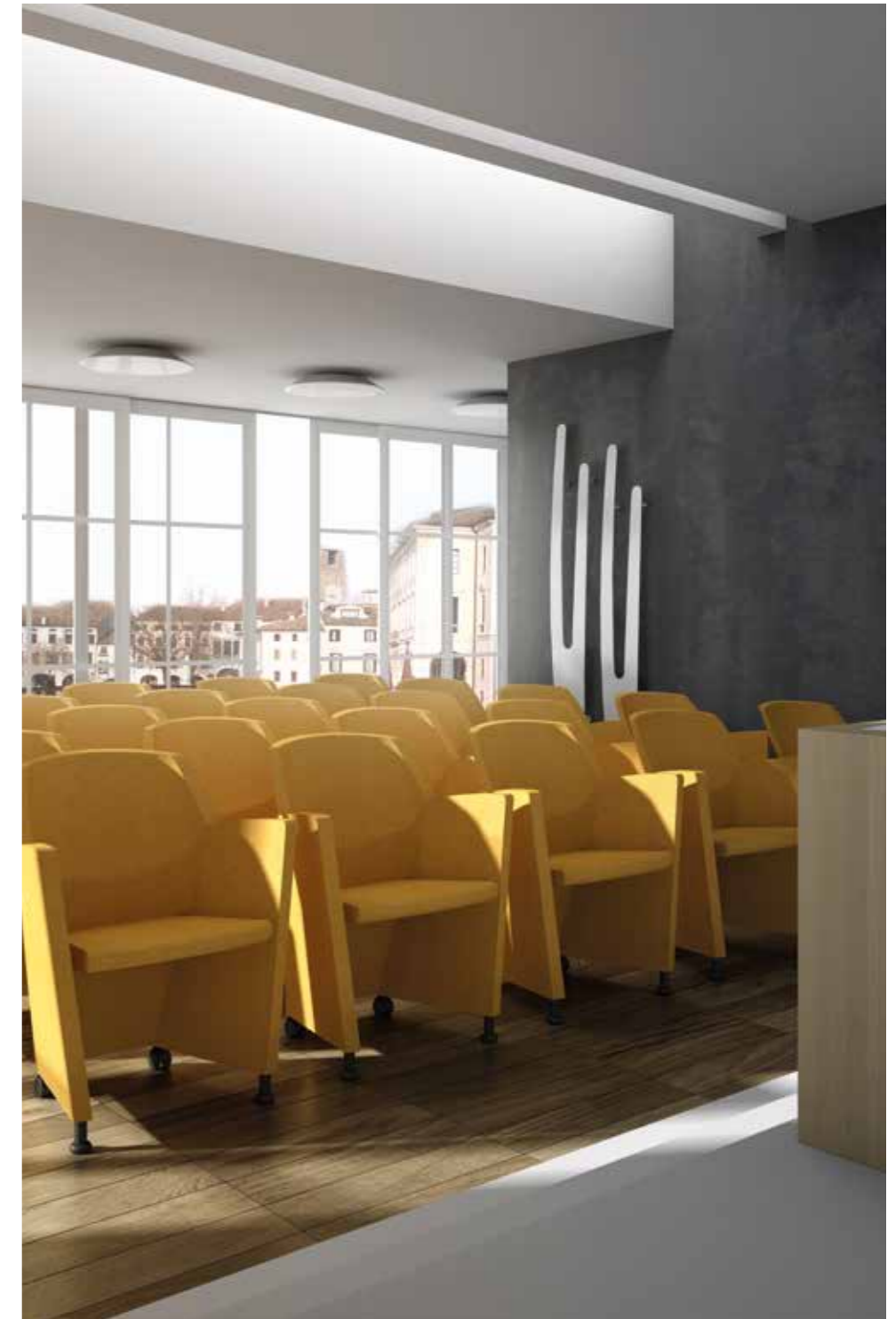

**clac** | *R&d Leyform*



Una pratica poltrona per sala convegni o meeting, dalle forme squadrate e semplici, richiudibile con pochi e semplici movimenti. Clac, nelle varianti su ruota e tavoletta è sempre pronta all'uso, occupando pochissimo spazio quando viene riposta al termine del suo utilizzo.

An useful armchair for meeting rooms or waiting areas. Clac is a folding chair easy to store after the use thanks to its minimal and geometric design: it is a practical space-saving solution. Customizable with castors and writing tablet.

Clac, une chauffeuse pour les salles d'attente ou les espaces conference. Avec ses lignes géométriques et simples, elle est rapidement refermable et toujours prête à l'emploi. Disponible avec roulettes et tablette porte PC. La chauffeuse qui va optimiser l'espace.

Ein praktisches Sessel für Konferenz- oder Meetingräume mit eckigen und schlichten Formen, das mit wenigen und einfachen Handgriffen zusammengeklappt werden kann. Clac in den Ausführungen auf Rollen und mit Schreibplatte ist stets einsatzbereit und benötigt nach der Benutzung nur wenig Platz.



Rivestimento in lana, tavoletta laterale opzionale  
Wool upholstery, optional side tablet  
Revêtement en laine, tablette latérale en option  
Stoffbezug aus Wolle, Optionales seitliches Tablar

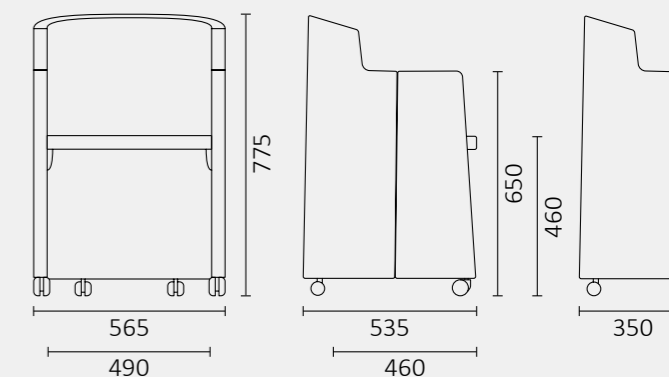



# operative | *Leyform*



star | 96



active | 100



sprint | 108



dad | 116



rush | 120



astra | 126



cometa | 130



wiki | 132



energy | 138



dinamica | 140



non stop | 142



## star | R&d Leyform



Essenzialismo e semplicità. Star garantisce ore di produttività senza alcun compromesso. La comoda seduta imbottita, lo schienale in rete traspirante, la pratica regolazione lombare, sono elementi che favoriscono una piacevolezza di utilizzo continuativa nel tempo, che ci accompagna nella giornata lavorativa.

Minimalism and simplicity. Star guarantees hours of productivity without compromise. The comfortable upholstered seat, the breathable mesh backrest and the practical lumbar adjustment are elements that make it a pleasure to use over time, throughout the working day.

Essentialisme et simplicité. Star garantit des heures de productivité sans compromis. L'assise rembourrée confortable, le dossier en maille respirante et le réglage lombaire pratique sont des éléments qui rendent son utilisation agréable dans le temps, en nous accompagnant pendant la journée de travail.

Essentialismus und Einfachheit. Star garantiert stundenlange Produktivität ohne Kompromisse. Der bequem gepolsterte Sitz, die atmungsaktive NetZRückenlehne und die praktische Lendenwirbelverstellung sind Elemente, die die Nutzung des Stuhls zu einem Vergnügen machen und uns durch den Arbeitstag begleiten.





**SCHIENALE**  
backrest / dossier / Rückenlehne



**BRACCIOLI**  
armrests / accoudoirs / Armlehnen



**BASAMENTI**  
bases / piétements / Fussgestelle



**POGGIATESTA**  
headrest / appui-tête / Kopfstütze



**COLORI PLASTICHE**  
plastic colours / couleurs plastique / Kunststofffarben



Schienale in rete, seduta imbottita e rivestita  
Mesh backrest, padded and upholstered seat  
Dossier en résille, assise rembourrée et tapissée  
Netzrückenlehne, gepolsterter Sitz

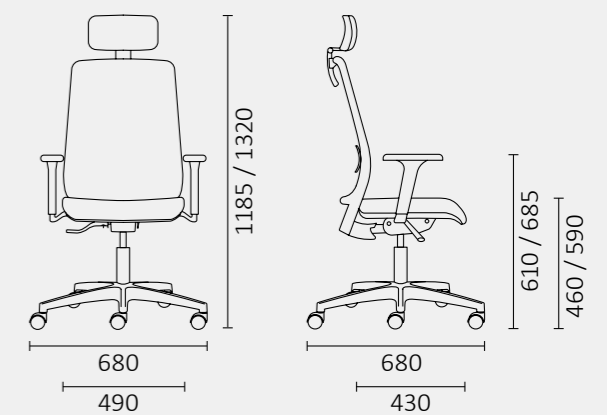
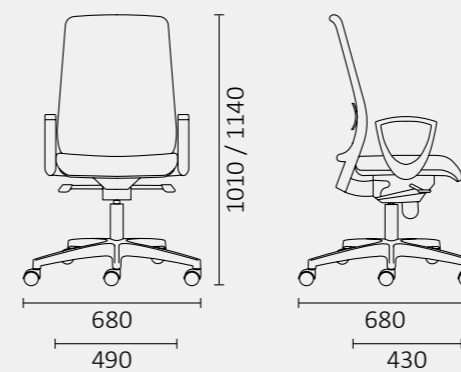

## active | R&d Leyform



Una nuova seduta operativa, con linee giovanili e dinamiche. Schienale imbottito o in rete, con verniciatura bianca oppure nera, Active entra nella collezione Leyform, portando freschezza, comodità e un'estetica estremamente attuale. Una struttura robusta e una praticità inconfondibile per rinnovare e migliorare il design della tua area lavorativa.

A new operational chair with fresh and dynamic lines. Upholstered or mesh backrest, Active joins the Leyform collection featuring freshness, comfort and a contemporary look. A sturdy body and an incomparable functionality to update and improve the design of your working environment.

Une nouvelle gamme opérationnelle aux lignes contemporaines et dynamiques, avec son dossier tapissé ou résille, verni blanc ou noir, Active entre dans la collection Leyform amenant une vague de fraîcheur un confort remarquable et une esthétique extrêmement actuelle. Une structure robuste et une fonctionnalité incomparables pour rénover et améliorer le design de votre espace de travail.

Ein neuer operationeller Drehstuhl mit kontemporärem und dynamischem Look. Active steigt in die Leyform Kollektion ein und bringt eine Frischewelle, erhöhten Komfort und aktuelle Ästhetik, mit. In die gepolsterte bzw. Netz-Rückenversionen und in der weißen bzw. schwarzer Ausführung erhältlich, Active bietet eine robuste Struktur und außergewöhnliche Funktionsfähigkeit, die das Design Ihrer Arbeitsräume hochbringt.

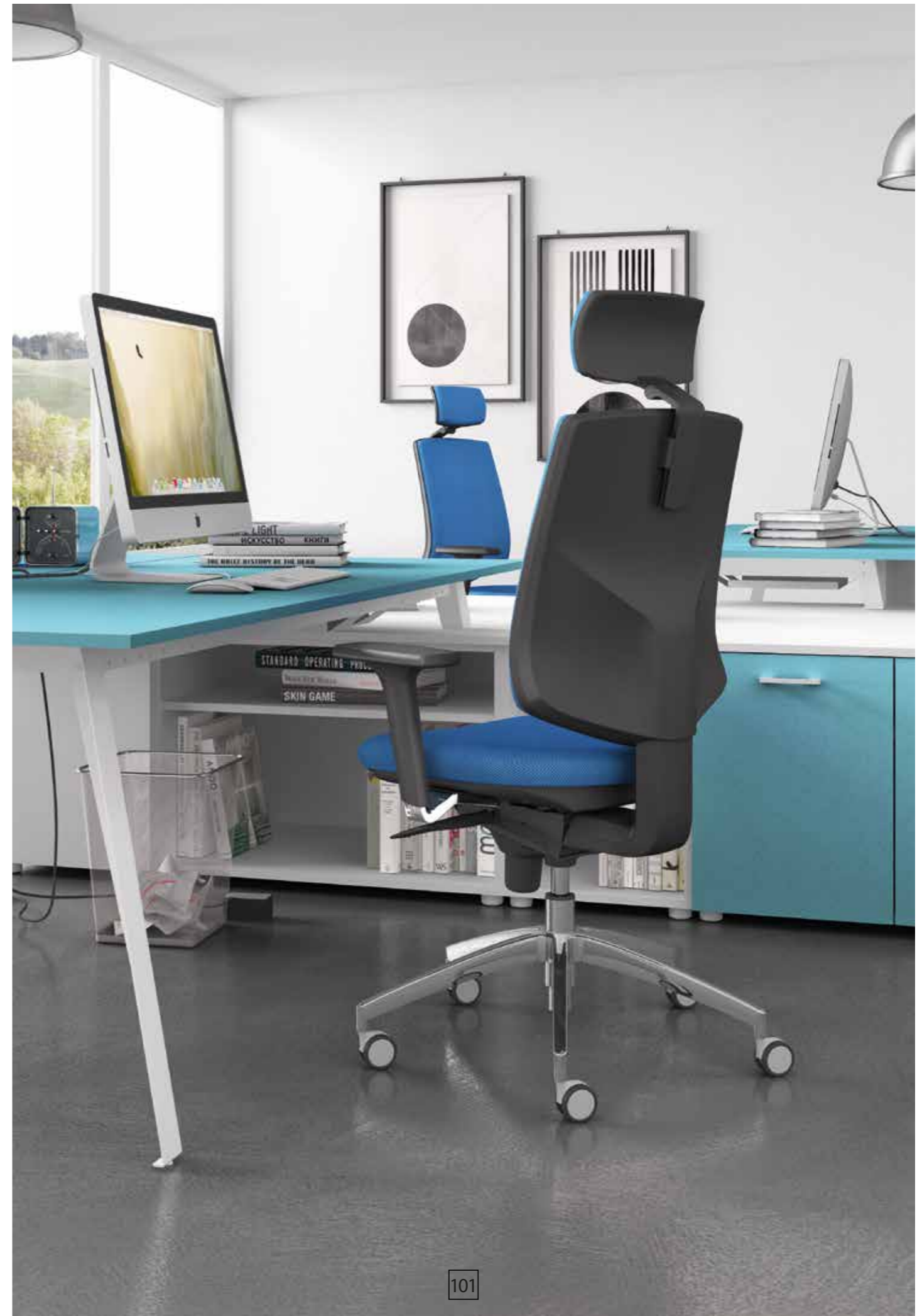





104

Seduta imbottita e rivestita, base girevole in alluminio  
 Padded and upholstered seat, swivel base in aluminium  
 Assise rembourrée et tapissée, Piétement en aluminium poli  
 Gepolsterter Sitz, Fusskreuz aus Aluminium



Dettaglio schienale,  
 seduta imbottita e rivestita  
 Backrest detail, padded  
 and upholstered seat  
 Détail du dossier, assise  
 rembourrée et tapissée  
 Detail der Rückenlehne,  
 gepolsterter Sitz

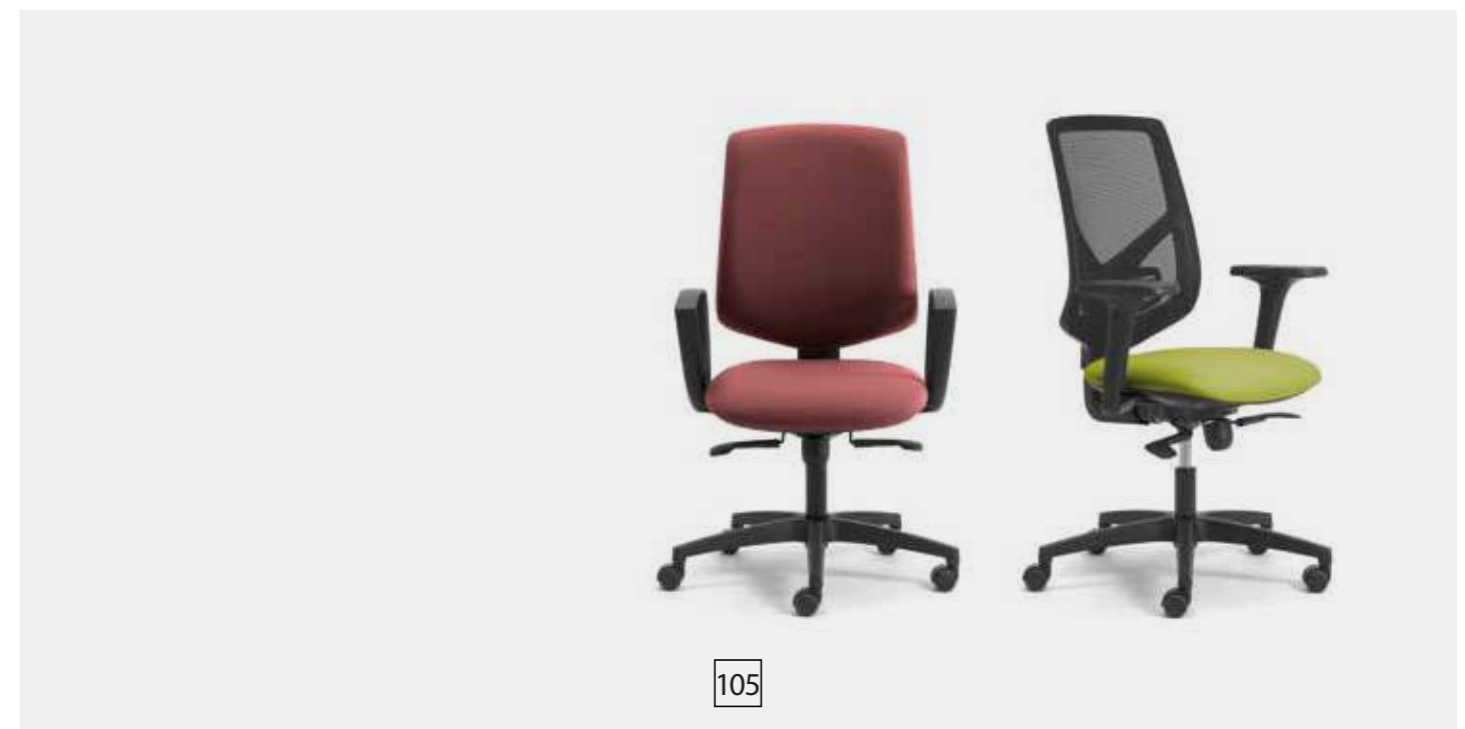

105



Schienale in rete, sedile in tessuto  
 Mesh backrest, seat in fabric  
 Dossier en résille, assise en tissu  
 Netzurückenlehne, Sitz aus Stoff

106



**SCHIENALE**  
 backrest / dossier / Rückenlehne



**BRACCIOLI**  
 armrests / accoudoirs / Armlehnen



**BASAMENTI**  
 bases / piétements / Fussgestelle

**POGGIATESTA**  
 headrest / appui-tête / Kopfstütze



**COLORI PLASTICHE**  
 plastic colours / couleurs plastique / Kunststofffarben

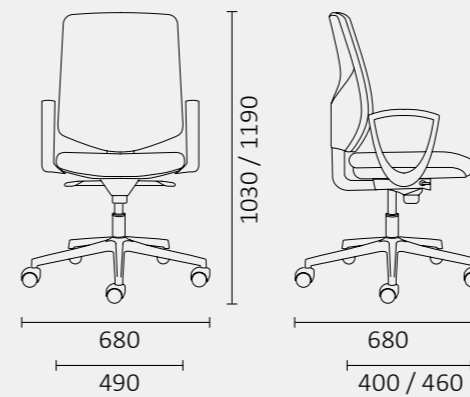

107

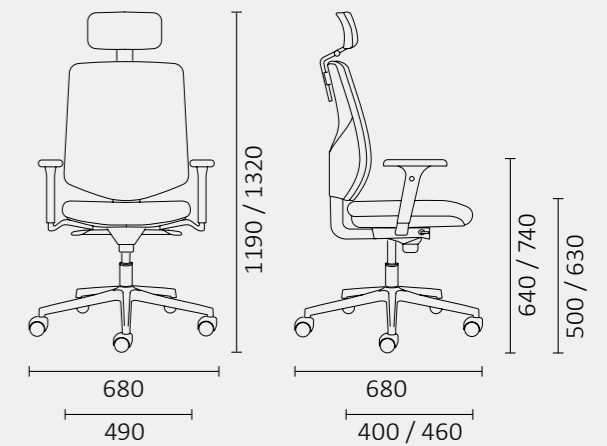

## sprint | R&d Leyform



Sprint è sinonimo di velocità, praticità e maneggevolezza. Un vero e proprio cavallo di battaglia che da anni viene apprezzato per la sua facilità di utilizzo. Una sedia che accompagna nella quotidianità con assoluta disinvoltura, e aiuta a districarsi nel difficile ambiente lavorativo.

Sprint: speed, functionality and manageability. A true workhorse appreciated for its easy use. A task office chair designed to respond to different user needs and to help in the difficult working environment... all day long.

Rapide, pratique et versatile. Un vrai cheval de bataille depuis des années, apprécié pour sa praticité. Le voilà, Sprint, le siège très connu et toujours apprécié pour sa simplicité, parfait pour l'emploi pendant toute la journée.

Sprint steht für Schnelligkeit, Zweckmäßigkeit und leichte Handhabung. Ein echtes Spitzenmodell, das sich dank seiner Benutzerfreundlichkeit seit Jahren großer Beliebtheit erfreut. Ein Stuhl, der lässig durch den Tag begleitet und das Zurechtfinden im Arbeitsplatzschwung erleichtert.









Braccioli fissi, base girevole in alluminio  
Fixed armrests, swivel base in aluminium  
Accoudoirs fixes, piétement  
en aluminium poli  
Fixe Armlehnen, Fusskreuz  
aus Aluminium





Braccioli regolabili, base girevole in alluminio  
Adjustable armrests, swivel base in aluminium  
Accoudoirs réglable, piétement en aluminium poli  
Verstellbare Armlehnen, Fusskreuz aus Aluminium



114

**SCHIENALE**  
backrest / dossier / Rückenlehne



**BRACCIOLI**  
armrests / accoudoirs / Armlehnen



**BASAMENTI**  
bases / piétements / Fussgestelle



**POGGIATESTA**  
headrest / appui-tête / Kopfstütze



**COLORI PLASTICHE**  
plastic colours / couleurs plastique / Kunststofffarben

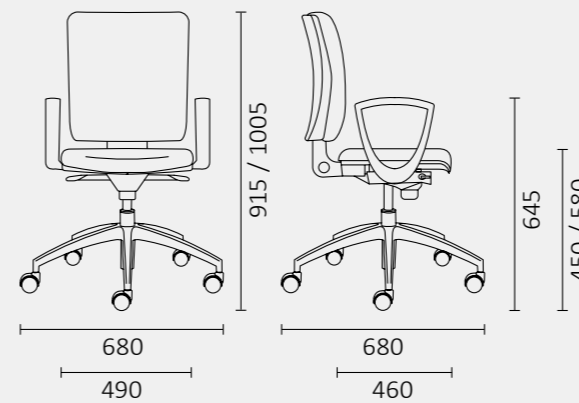

115

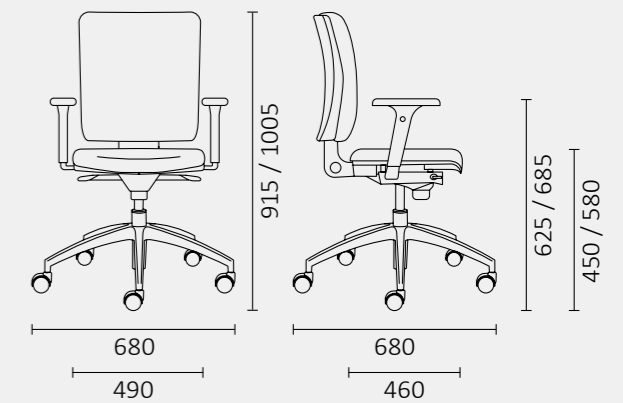

## dad | R&d Leyform



Semplicità, leggerezza, praticità. Non è mai banale riuscire a coniugare questi tre concetti in un unico prodotto. Dad ci riesce benissimo, grazie al look pulito e ad una facile trasportabilità e configurazione. Lo smart working è più bello con il giusto mix tra design e comodità.

Simplicity, lightness and practicality. It is far from easy to combine these three concepts in one product. Dad does so brilliantly, thanks to its clean look, its easy portability and the many configurations. Working from home has never been so nice with the right mix of design and comfort.

Simplicité, légèreté, praticité. Il n'est jamais facile de pouvoir combiner ces trois concepts en un seul produit. Dad le fait très bien, grâce à son apparence épurée et à sa portabilité et à sa configuration faciles. Smart working est plus agréable avec le bon mix de design et de confort.

Einfachheit, Leichtigkeit, Bequemlichkeit. Es ist nie einfach, diese drei Konzepte in einem einzigen Produkt kombinieren zu können. Dad kombiniert dies hervorragend, dank des sanften Aussehens und der einfachen Beweglichkeit und Konfiguration. Smart working ist noch angenehmer mit dem richtigen Mix aus Design und Komfort.





Schienale imbottito e rivestito, base girevole in nylon nero  
 Padded and upholstered backrest, swivel base in black nylon  
 Dossier rembourré et tapissé, piétement en nylon noir  
 Gepolsterte Rückenlehne, Fusskreuz aus schwarzem Kunststoff

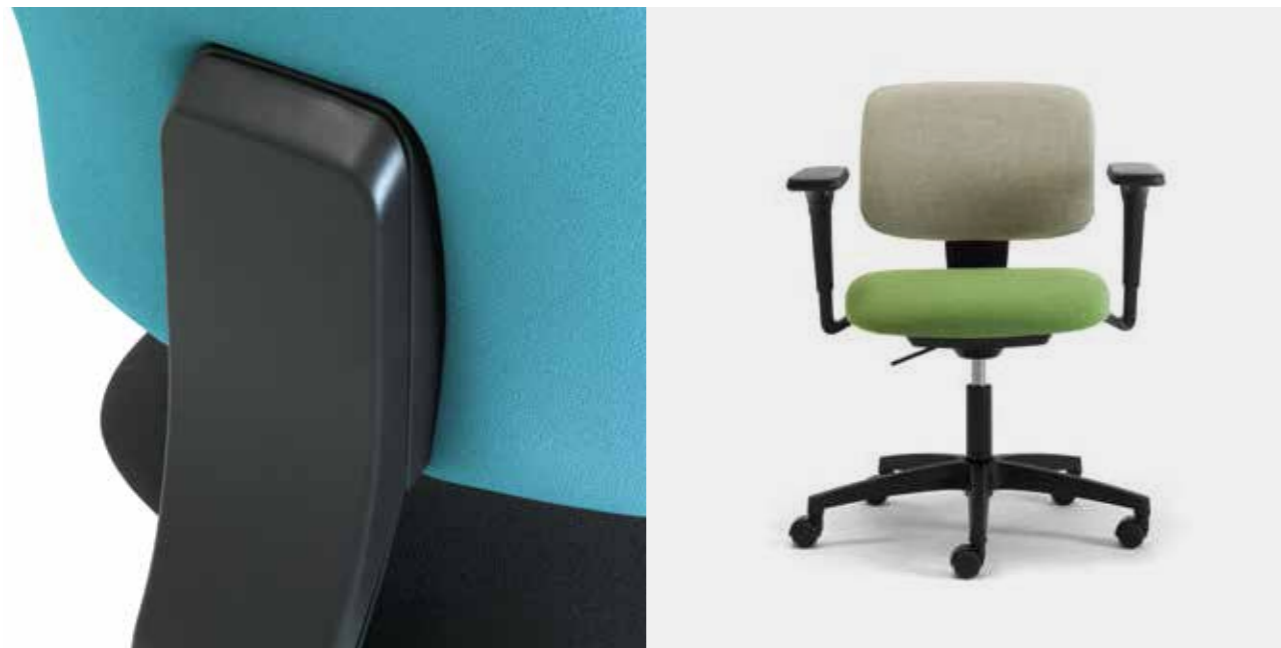

118

**REGOLAZIONI DAD**  
 functions / fonctions / Verstellungen



**REGOLAZIONI DAD PLUS**  
 functions / fonctions / Verstellungen



**BRACCIOLI**  
 armrests / accoudoirs / Armlehnen



**BASAMENTI**  
 bases / piétements / Fussgestelle



**COLORI PLASTICHE**  
 plastic colours / couleurs plastique / Kunststofffarben

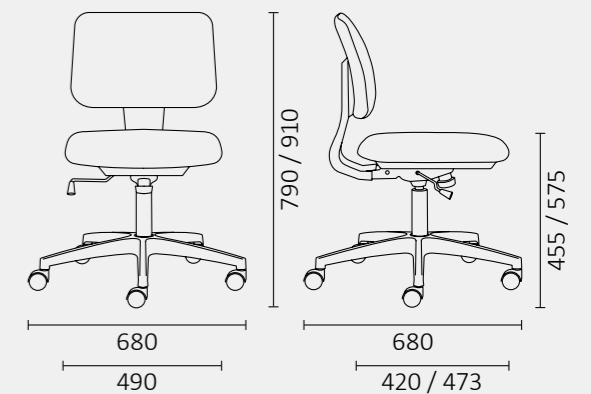
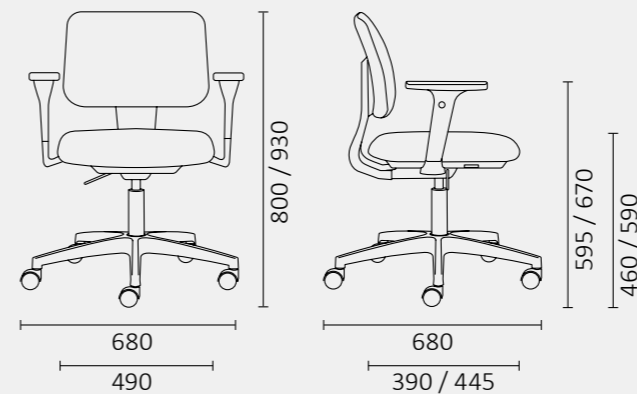

119

## rush | *R&d Leyform*



Forme arrotondate per descrivere una nuova seduta operativa, disponibile nella versione con schienale imbottito e in rete, e in plastiche bianche o nere. Rush propone un approccio informale e un design minimal allo spazio lavorativo, dando importanza alla comodità, grazie al nuovo bracciolo e al pratico poggiatesta.

Rounded forms to describe a new operational chair, available in versions with padded or mesh backrests, and in white or black plastics. Rush proposes an informal approach and a minimal design to the workspace, giving importance to comfort, thanks to the new armrest and practical headrest.

Des formes arrondies pour décrire une nouvelle chaise de travail, disponible avec un dossier rembourré ou en résille, et en plastique blanc ou noir. Rush propose une approche informelle et un design minimaliste de l'espace de travail, tout en privilégiant le confort, grâce au nouvel accoudoir et à l'appui-tête pratique.

Abgerundete Formen, um einen neuen Bürostuhl zu beschreiben, der mit gepolsterter oder Netzrückenlehne und in weißem oder schwarzem Kunststoff erhältlich ist. Rush bietet einen informellen Ansatz und ein minimalistisches Design für den Arbeitsplatz, wobei der Komfort dank der neuen Armlehne und der praktischen Kopfstütze im Vordergrund steht.







**SCHIENALE**  
backrest / dossier / Rückenlehne



**BASAMENTO**  
bases / piétements / Fussgestelle



**POGGIATESTA**  
headrest / appui-tête / Kopfstütze



**COLORI PLASTICHE**  
plastic colours / couleurs plastique / Kunststofffarben



124

Braccioli regolabili, seduta imbottita e rivestita  
Adjustable armrests, padded and upholstered seat  
Accoudoirs réglables, assise rembourrée et tapissée  
Verstellbare Armlehnen, gepolsterter Sitz

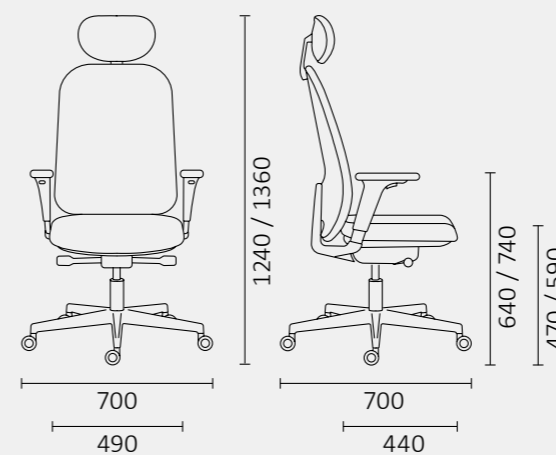

125

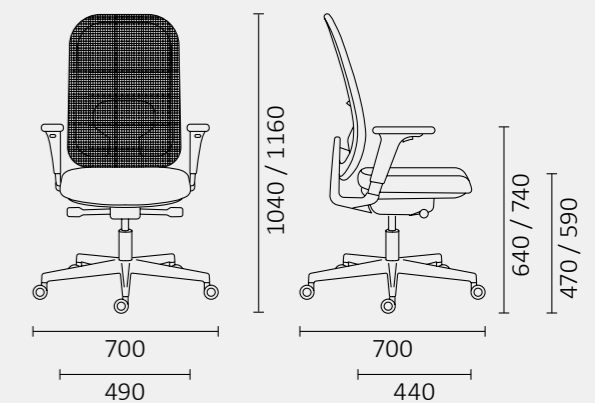



## **astra** | *Massimo Costaglia e Giulia Mazzanti*



Astra è una ventata di puro design nell'area operativa, grazie ad uno speciale meccanismo completamente a scomparsa che restituisce linee pulite ed essenziali. La sua struttura snodata e i braccioli ribaltabili inoltre assecondano i movimenti del corpo, che si fanno più fluidi e pronti in ogni direzione.

Astra brought a real breath of design and aesthetic in our operative range, with a completely hidden mechanism resulting in clean and essential lines. Its special frame combined with the innovative armrests allows to fit and adapt with the body movements, making them smooth and ready in every directions.

Astra est un souffle de design pur dans la zone opérationnelle, grâce à un mécanisme spécial entièrement caché qui renvoie des lignes épurées et essentielles. Sa structure articulée et ses accoudoirs innovatives soutiennent également les mouvements du corps, qui deviennent plus fluides et prêts dans toutes les directions.

Astra ist ein Hauch von purem Design im Einsatzbereich, dank eines speziellen, vollständig versteckten Mechanismus, ergibt er klare und wichtige Linien. Die Gelenkstruktur und die innovativen Armlehnen unterstützen auch die Bewegungen des Körpers in jeder Richtung.





**SCHIENALE**  
backrest / dossier / Rückenlehne



**REGOLAZIONI**  
functions / fonctions / Verstellungen



**COLORI PLASTICHE**  
plastic colours / couleurs plastique / Kunststofffarben



Schienale in rete, seduta imbottita e rivestita  
Mesh backrest, padded and upholstered seat  
Dossier en résille, assise rembourrée et tapissée  
Netzrückenlehne, gepolsterter Sitz

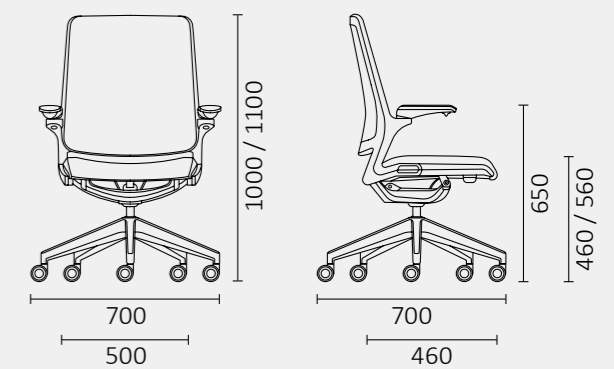

Schienale in rete, base  
girevole in alluminio  
Mesh backrest, Swivel  
base in aluminium  
Dossier en résille, Piétement  
en aluminium poli  
Netzrückenlehne,  
Fusskreuz aus Aluminium

**cometa** | *R&d Leyform*



La seduta operativa per  
eccellenza. Una grande quantità  
di varianti permettono una  
completa personalizzazione di  
basamento, seduta e schienale.  
Impeccabile anche in ambito  
semidirezionale, Cometa arreda  
l'ufficio con una forte presenza  
scenica. Sempre al centro  
dell'attenzione.

The office chair. Cometa is the  
great furnishing solution also  
for directional workspaces,  
a chair with multiple finish  
possibilities. She is a star, always  
in the spotlight.

Le siège opératif par excellence.  
Base, assise et dossier à  
personnaliser grâce aux  
nombreux caractéristiques.  
Parfait aussi comme siège de  
direction véritable, Cometa:  
l'étoile du bureau, toujours au  
centre de l'attention.

Der Drehstuhl par excellence.  
Eine große Vielfalt an  
Eigenschaften erlaubt die  
vollkommene Personalisierung  
von Fußgestell, Sitz und  
Rückenlehne. Cometa  
macht auch beim mittleren  
Management eine gute Figur  
und richtet das Büro perfekt ein.  
Ein echter Hingucker.

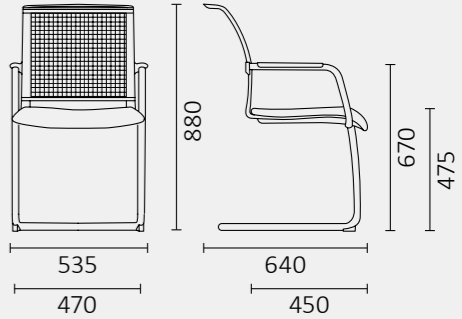
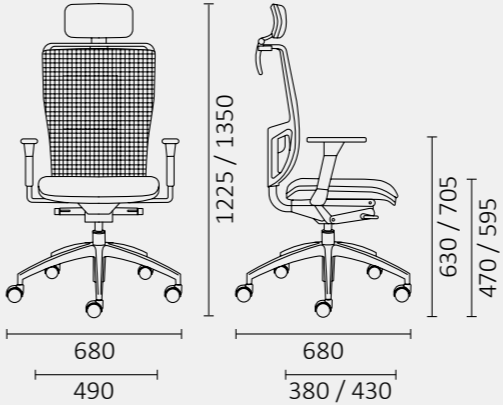

## wiki | R&d Leyform



Estrema versatilità grazie alla struttura in nylon e la seduta personalizzabile in più di 80 diversi tessuti e colorazioni. Wiki è la compagna ideale nell'ambiente ufficio, una solida configurazione e un nuovo comfort permettono di lavorare in piena armonia, arredando lo spazio lavorativo come mai prima d'ora.

A dynamic and versatile office chair thanks to its nylon frame and the customisable seat in more than 80 different fabrics and colors. Wiki offers stability, comfort and design, thus ideally decorating your workspace and allowing to work harmoniously.

Structure en nylon et assise personnalisable en choisissant parmi 80 différents couleurs et tissus. Wiki: le siège parfait pour le bureau. Une structure solide et un nouvel confort pour travailler en harmonie et meubler son bureau comme jamais.

Extreme Vielseitigkeit dank einem Gestell aus Nylon und einem mit mehr als 80 verschiedenen Stoffen und Farben personalisierbaren Sitz. Wiki ist der ideale Begleiter im Büro. Eine solide Konfiguration und ein neuer Komfort erlauben es, in perfekter Harmonie zu arbeiten und gleichzeitig den Arbeitsbereich auf noch nie da gewesene Weise einzurichten.



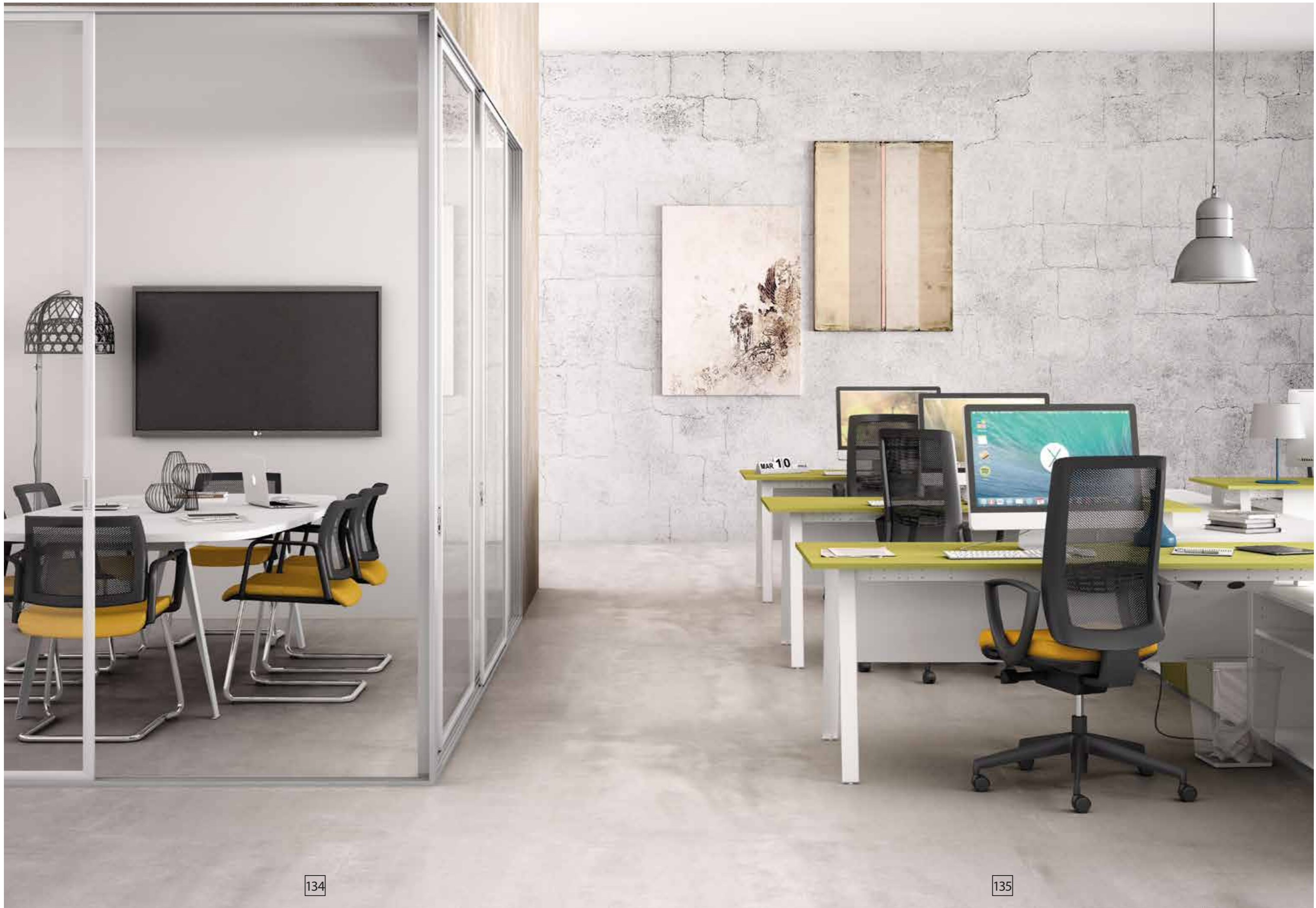



**SCHIENALE**  
backrest / dossier / Rückenlehne



**BASAMENTI**  
bases / piétements / Fussgestelle



**ATTESA**  
lounges / visiteur / Besuchersessel



**POGGIATESTA**  
headrest / appui-tête / Kopfstütze



Schienale imbottito, rivestimento in tessuto  
Padded backrest, fabric cover  
Dossier rembourré, revêtement en tissu  
Gepolsterte Rückenlehne, Stoffbezug

136

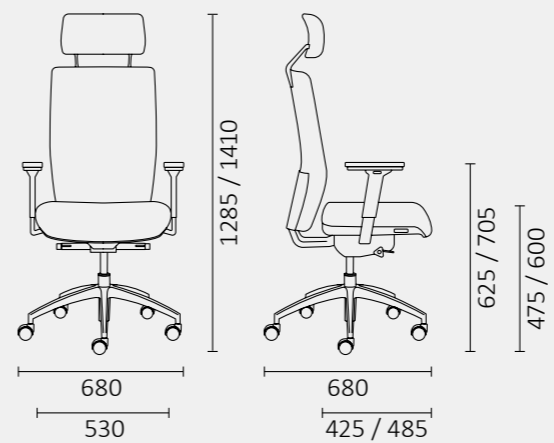

137

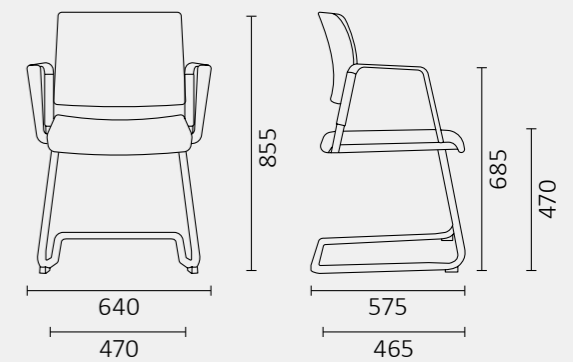

# energy | R&d Leyform



Lo schienale è il suo punto di forza. Grazie alla sua linea sinuosa Energy si adatta perfettamente alle curve del corpo regalando un comfort unico e impagabile. La forma divertente del bracciolo fisso crea un tutt'uno con la scocca. Il risultato è la sedia perfetta per un ambiente dinamico ed eccentrico.

Energy offers an exclusive and modern design. Its strength is the ergonomic backrest synchronising with your body for a perfect comfort. The amazing armrest features a modern look for a dynamic space.

Sa force est son dossier: grâce à la sinuosité de ses formes Energy s'adapte aux courbes à l'anatomie du corp en assurant un confort unique et insurmontable. L'accoudoir fixe forme une ligne unique avec la structure. Le résultat est là: un siège parfait pour un bureau dynamique et excentrique.

Die Rückenlehne ist seine Stärke. Dank seiner geschwungenen Linie passt sich Energy den Körperformen perfekt an und bietet einen einzigartigen und unbezahlbaren Komfort. Die ansprechende Form der fixen Armlehne bildet eine Einheit mit der Schale. Das Ergebnis ist der perfekte Stuhl für ein dynamisches und extravagantes Ambiente.

Braccioli fissi,  
Base girevole in nylon nero  
Fixed armrests,  
Swivel base in black nylon  
Accoudoirs fixes,  
Piètement en nylon noir  
Fixe Armlehnen,  
Fusskreuz aus schwarzem Kunststoff

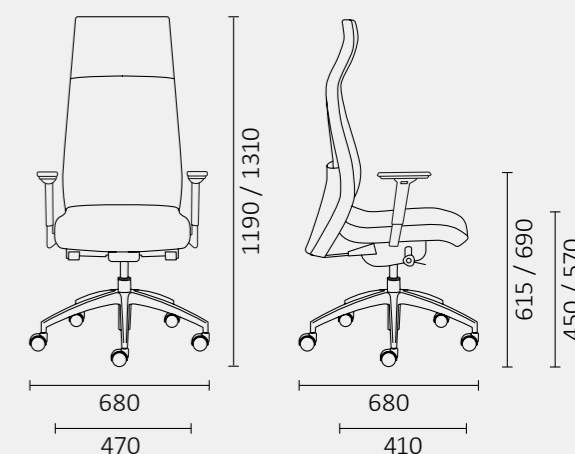
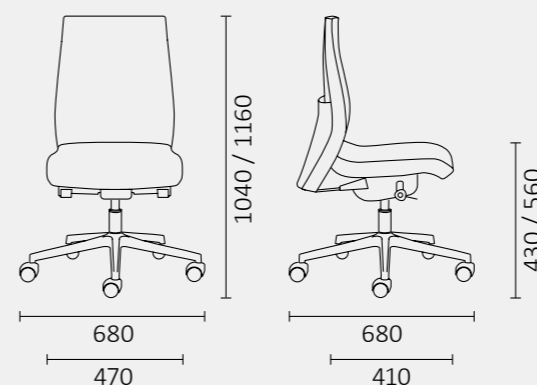

Imbottitura in tessuto,  
 base girevole in alluminio  
 Upholstery in fabric,  
 swivel base in aluminium  
 Revêtement en tissu,  
 piétement en aluminium poli  
 Polsterung aus Stoff,  
 Fusskreuz aus Aluminium

## dinamica | R&d Leyform



Un prodotto tecnologico  
 all'avanguardia, estermamente  
 personalizzabile. Dinamica  
 offre la regolazione dell'altezza  
 del supporto lombare e la  
 possibilità di modificare  
 l'angolazione del poggiatesta.  
 Finalmente è possibile adattare  
 la sedia al proprio stile di vita.  
 Qualunque esso sia.

Dinamica, a dynamic office  
 chair combining new  
 productive technologies and  
 new confort thanks to its  
 mechanism which provides  
 encompassable ergonomic  
 features. The perfect chair for  
 any lifestyle.

Dinamica est un siège conçu  
 sur la base des dernières  
 technologies et aussi  
 personnalisable: support  
 lombaire et tête réglables  
 pour l'adapter à votre image,  
 quelle qu'elle soit.

Ein hochmodernes  
 technologisches Produkt,  
 das individuell gestaltet  
 werden kann. Dinamica  
 bietet die Höhenverstellung  
 der Lordosenstütze und die  
 Möglichkeit, den Winkel der  
 Kopfstütze zu verändern.  
 Endlich kann der Stuhl an den  
 eigenen Lebensstil angepasst  
 werden. Egal, wie dieser  
 aussieht.

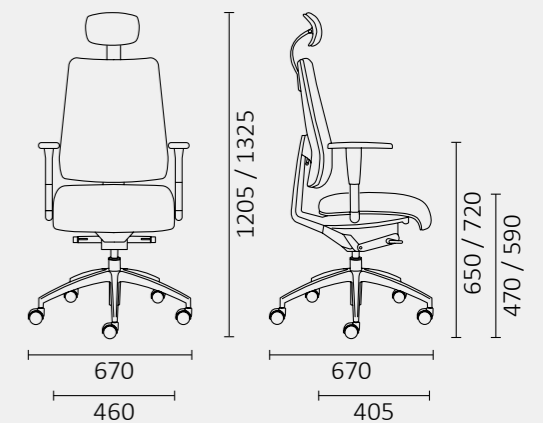
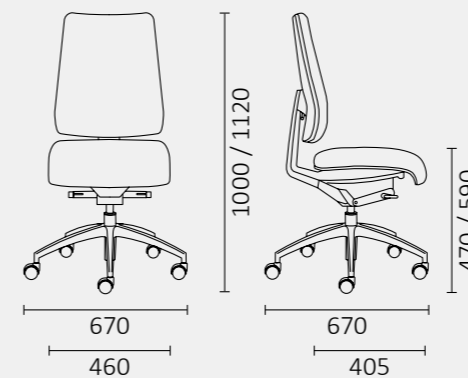
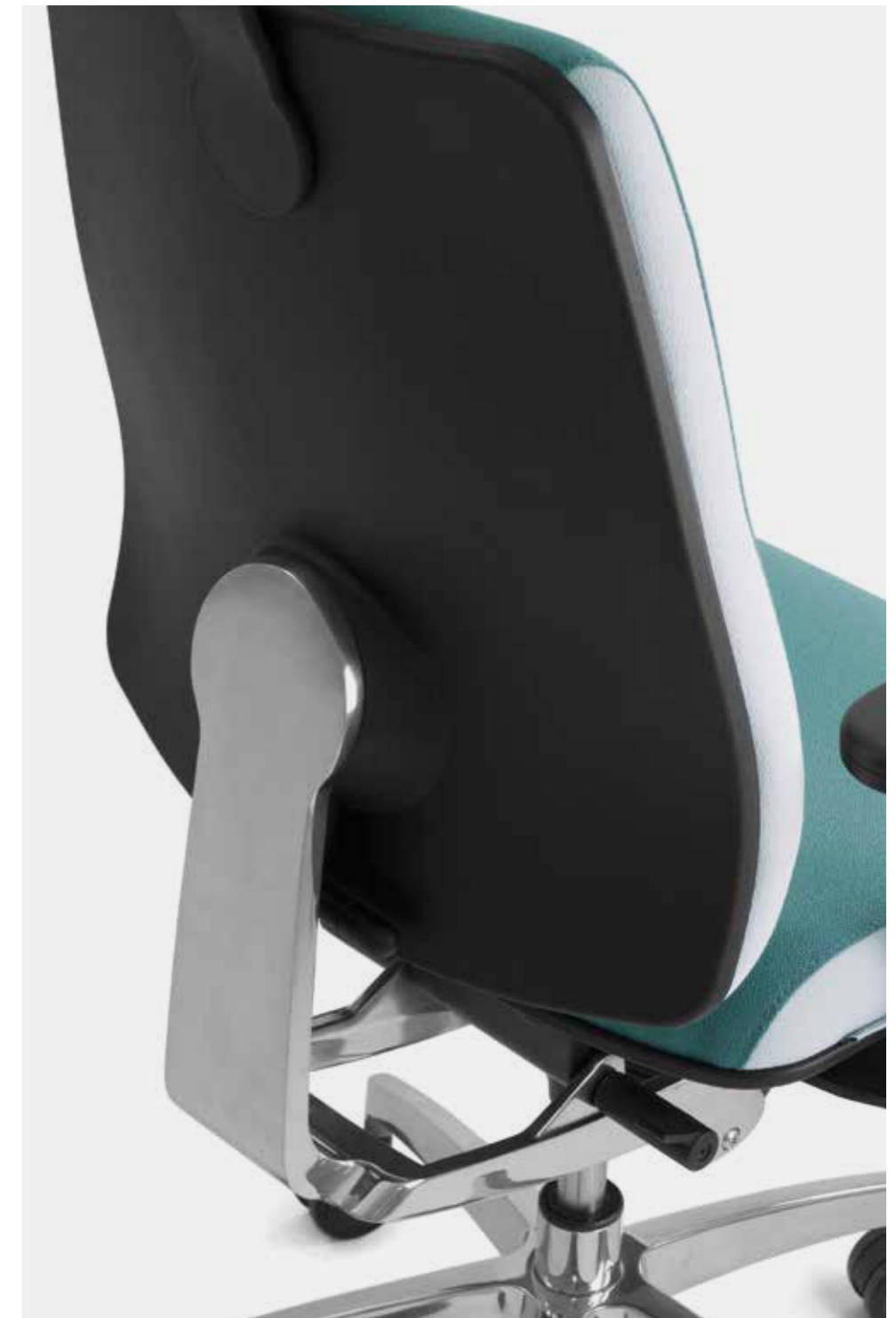



# non stop | R&d Leyform



Una vera fuoriserie. Non stop è la seduta perfetta per il duro lavoro, e garantisce una robustezza immutabile nel tempo. È sempre in movimento, e nonostante l'utilizzo intenso conserva la comodità e la praticità del primo giorno. Davvero infaticabile.

Why stop? This is the perfect chair to work and work... comfortably. Strength, functionality and comfort at all time, despite the intense use it is a robust and dynamic chair: Non Stop, a true workaholic.

Exceptionnelle. Non Stop est le véritable siège 24 heures: très solide et inaltérable, en dépit de l'utilisation elle est toujours robuste, confortable et pratique comme le premier jour. Tout simplement infatigable.

Ein echtes Ausnahmmodell. Non stop ist der perfekte Sitz für harte Arbeit und garantiert eine dauerhaft unveränderliche Robustheit. Stillstand ist keine Option und trotz einer intensiven Benutzung behält er die Bequemlichkeit und Zweckmäßigkeit wie am ersten Tag. Einfach unermüdlich.



Imbottitura in tessuto, braccioli regolabili  
Upholstery in fabric, adjustable armrests  
Revêtement en tissu, accoudoirs réglables  
Polsterung aus Stoff, verstellbare Armlehnen

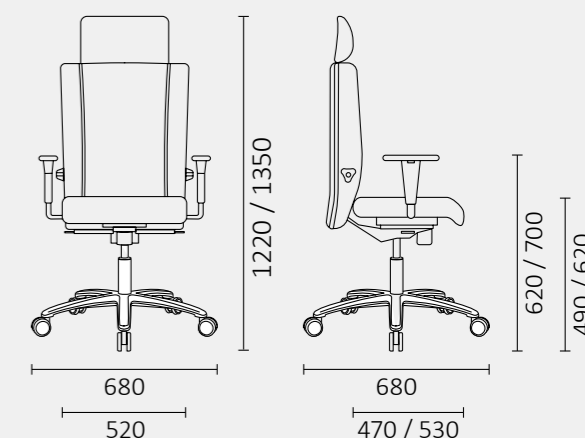
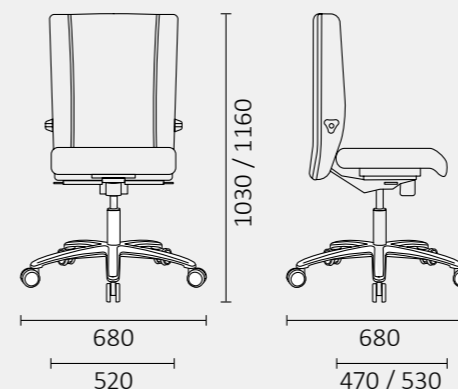

# direzionali | *Leyform*



alisè | 146



opera | 154



gaia | 162



aura | 170



wave | 176



zeus | 180



origami | 184



elegance | 194



doge | 196



## alisè | *Nicola Cacco*



Ambizione e perseveranza. Gusto e ricercatezza. Alisè non è una semplice seduta, ma è molto di più. È un viaggio che inizia nel mondo ufficio e finisce nella casa. Una famiglia trasversale di articoli che si muove tra forme morbide e scultoree al contempo, senza rinunciare al comfort e al piacere di utilizzo.

Ambition and perseverance. Taste and elegance. Alisè is not just a chair, it's much more. It's a journey that begins in the office and ends at home. A transversal family of products that moves between forms that are soft and sculptural at the same time, without sacrificing comfort and pleasure of use.

Ambition et persévérance. Goût et élégance. Alisè n'est pas seulement un fauteuil, c'est beaucoup plus. C'est un voyage qui commence dans le monde du bureau et se termine à la maison. Une famille transversale d'articles avec des formes douces et sculpturales au même temps, sans renoncer au confort et au plaisir d'utilisation.

Ehrgeiz und Beharrlichkeit. Geschmack und Raffinesse. Alisè ist nicht nur ein Sessel, er ist viel mehr. Es ist eine Reise, die in der Bürowelt startet und in den eigenen Wohnung endet. Eine transversale Familie von Artikeln, die sich gleichzeitig zwischen weichen und skulpturalen Formen bewegt, ohne dabei auf Komfort und Vergnügen zu verzichten.







Dettaglio schienale, rivestimento in lana  
Backrest detail, wool upholstery  
Détail du dossier, revêtement en laine  
Detail der Rückenlehne, Stoffbezug aus Wolle



Differenti dimensioni e altezze dello schienale  
Different sizes and heights of backrest  
Différentes tailles et hauteurs du dossier  
Verschiedene Größen und Höhen der Rückenlehne

150



151



**SCHIENALE**  
backrest / dossier / Rückenlehne



**SCHIENALE LOUNGE**  
lounge backrest / dossier lounge / Loungerückenlehne



**BASAMENTI**  
bases / piétements / Fussgestelle

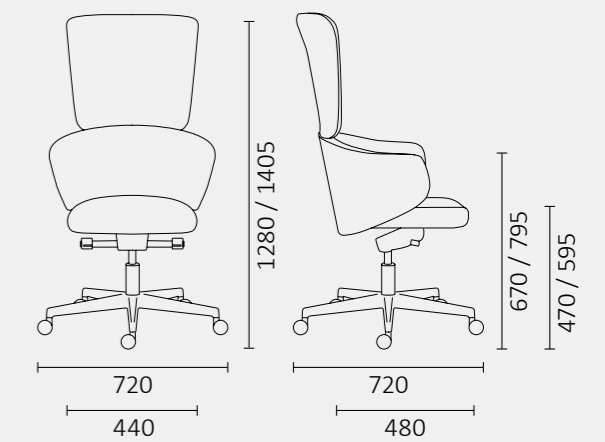
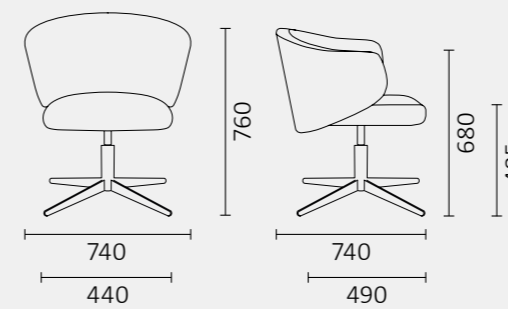

## opera | *Stefano Sandonà e Sabrina Bettini*



Un guscio avvolgente, che racchiude la schiena grazie alle sue forme sinuose. La famiglia Opera apre un nuovo capitolo tra le sedute direzionali Leyform. Un nuovo modo di intendere la comodità, attraverso linee fluide che scolpiscono la materia, capaci di disegnare una forma solida e plastica allo stesso tempo.

An enveloping shell, that embraces the entire back thanks to its sinuous design. The Opera collection opens a new chapter in Leyform executive chairs. A new way of conceiving the comfort through fluid lines that sculpt the matter, capable of designing, at the same time, a solid, yet soft shape.

Une coque enveloppant qui contient le dos grâce à sa forme sinueuse. La collection Opera ouvre un nouveau chapitre dans le segment Direction de Leyform. Une nouvelle façon de concevoir le confort à travers des lignes fluides qui sculptent la matière, capables de dessiner une forme solide et souple au même temps.

Eine umhüllende Schale, die den Rücken dank ihrer geschwungenen Formen umschließt. Die Opera-Kollektion eröffnet ein neues Kapitel unter Leyform Chefsesseln. Eine neue Art, den Komfort zu interpretieren, durch fließende Linien, die das Material meißeln und eine solide und gleichzeitig weiche Form zeichnen.









158

Rivestimento in lana, base girevole in alluminio  
 Wool upholstery, swivel base in aluminium  
 Revêtement en laine, piétement en aluminium poli  
 Stoffbezug aus Wolle, Fusskreuz aus Aluminium



Dettaglio bracciolo,  
 rivestimento in lana  
 Armrest detail, wool upholstery  
 Détail du accoudoir,  
 revêtement en laine  
 Detail der Armlehnen,  
 Stoffbezug aus Wolle

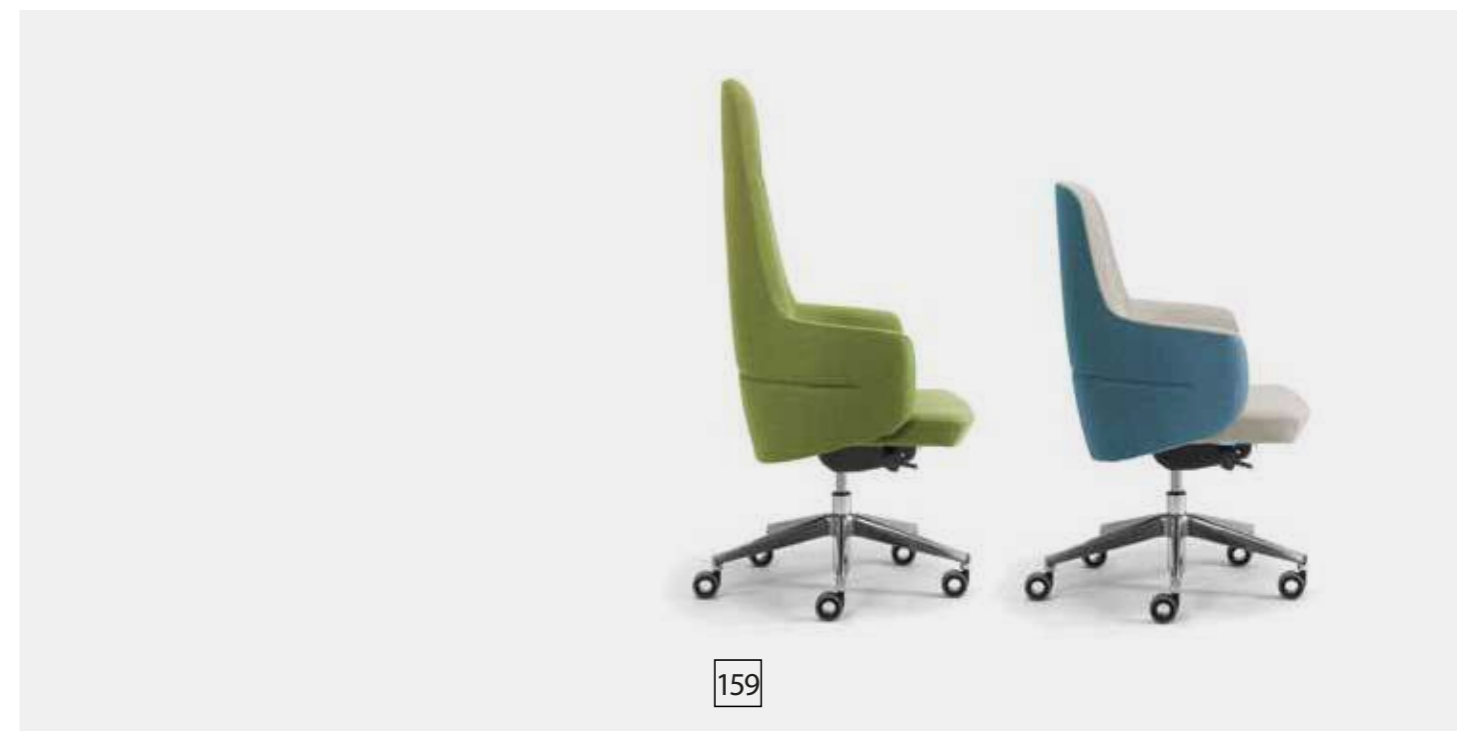

159



Dettaglio bracciolo, rivestimento in lana  
 Armrest detail, wool upholstery  
 Détail du accoudoir, revêtement en laine  
 Detail der Armlehnen, Stoffbezug aus Wolle



160

**SCHIENALE**

backrest / dossier / Rückenlehne



**CORDINO**

pipng / passepoil / Keder



**BICOLORE**

two-tone colour upholstery / revêtement bi-couleur / zweifarbige Bezugsfarben



**BASAMENTI**

bases / piétements / Fussgestelle

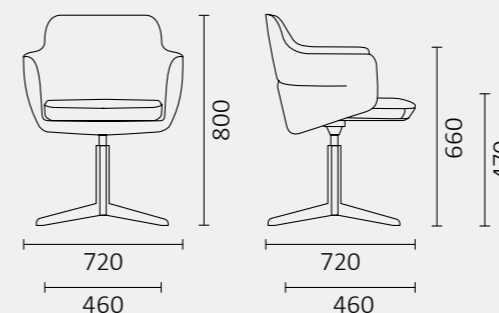

161

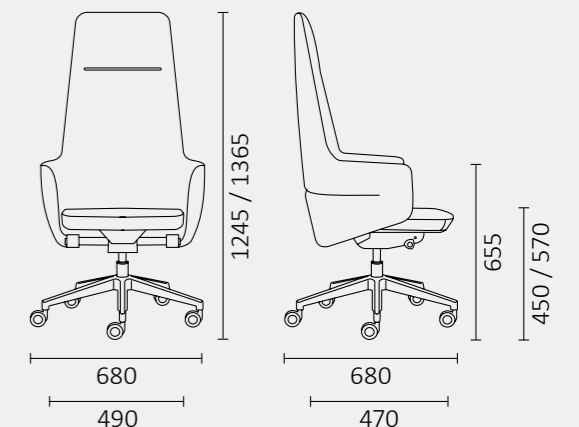

## gaia | *Giovanni Baccolini*



Un nuovo prodotto che unisce idealmente ufficio e casa. Scegli tra una comoda poltrona direzionale a due differenti altezze, una pratica seduta attesa con base metallica o in legno ed un elegante divano. Gaia combina il meglio dell'eleganza stilistica al comfort delle sue forme avvolgenti.

A new product that ideally unites office and home. Choose from a comfortable executive armchair with two different heights, a practical waiting chair with a metal or wooden base, and an elegant sofa. Gaia combines the best of stylistic elegance with the comfort of its enveloping forms.

Un nouveau produit qui réunit idéalement le bureau et la maison. Choisissez entre une fauteuil de direction confortable avec deux hauteurs différentes, une chaise d'attente pratique avec une piétement en métal ou en bois et un élégant canapé. Gaia combine le meilleur de l'élégance stylistique avec le confort de ses lignes fluides.

Ein neues Produkt, das Büro und Home vereint. Wählen Sie zwischen einem bequemen Chefsessel mit zwei verschiedenen Höhen, einem praktischen Wartesessel mit Metall- oder Holzgestell und einem eleganten Sofa. Gaia kombiniert Eleganz mit Komfort in seinen umhüllenden Formen.

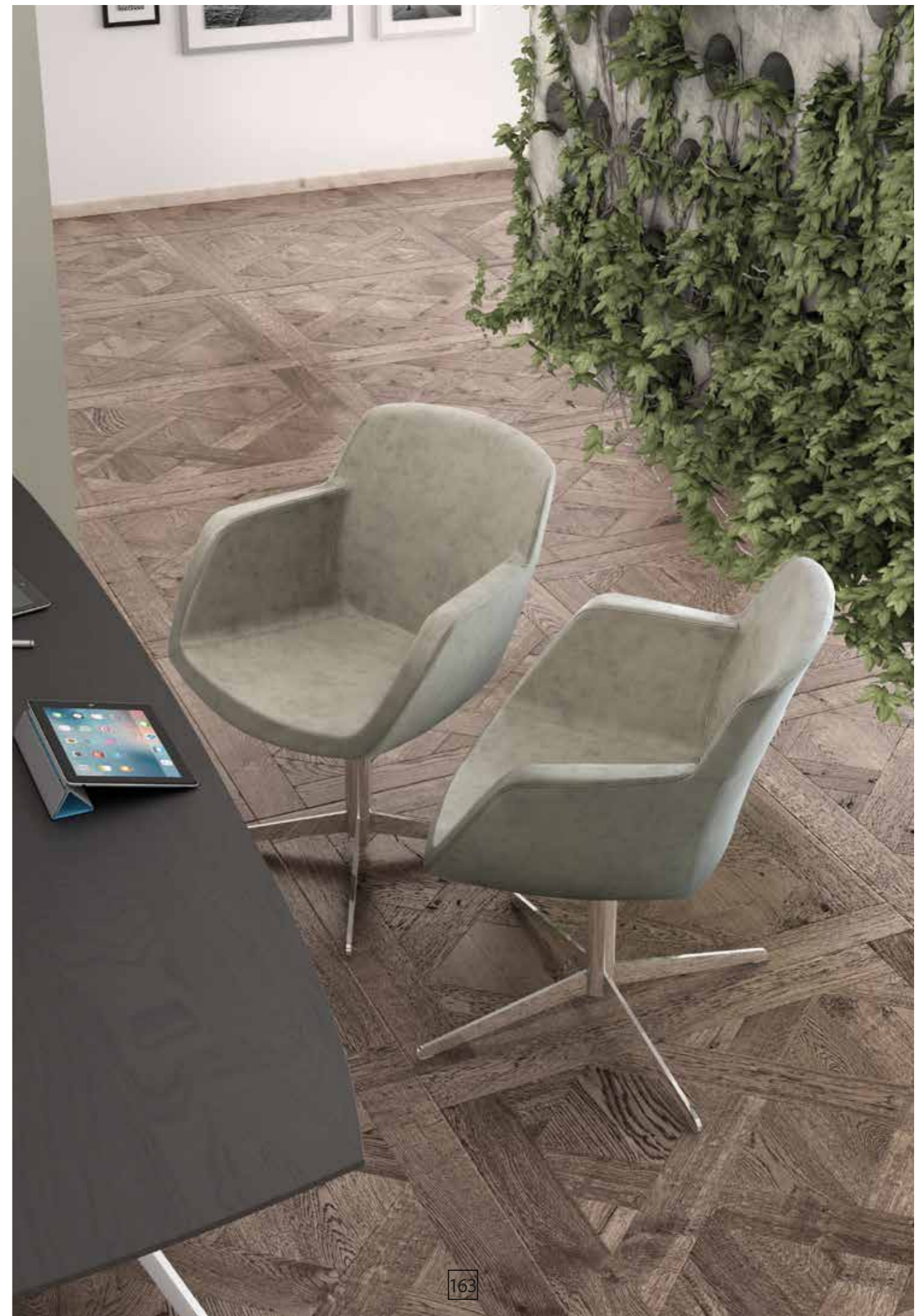





Versione girevole, base 4 razze  
 Swivel version, 4-star base  
 Version giratoire, piètement à 4 branches  
 Drehstuhlversion, 4-Fussfusskreuz



Monoscocca imbottita e rivestita, Base girevole in alluminio  
 Padded and upholstered shell, Swivel base in aluminium  
 Monocoque rembourré et tapissée,  
 Piètement en aluminium poli  
 Gepolsterter Formschalenstuhl, Fusskreuz aus Aluminium

166

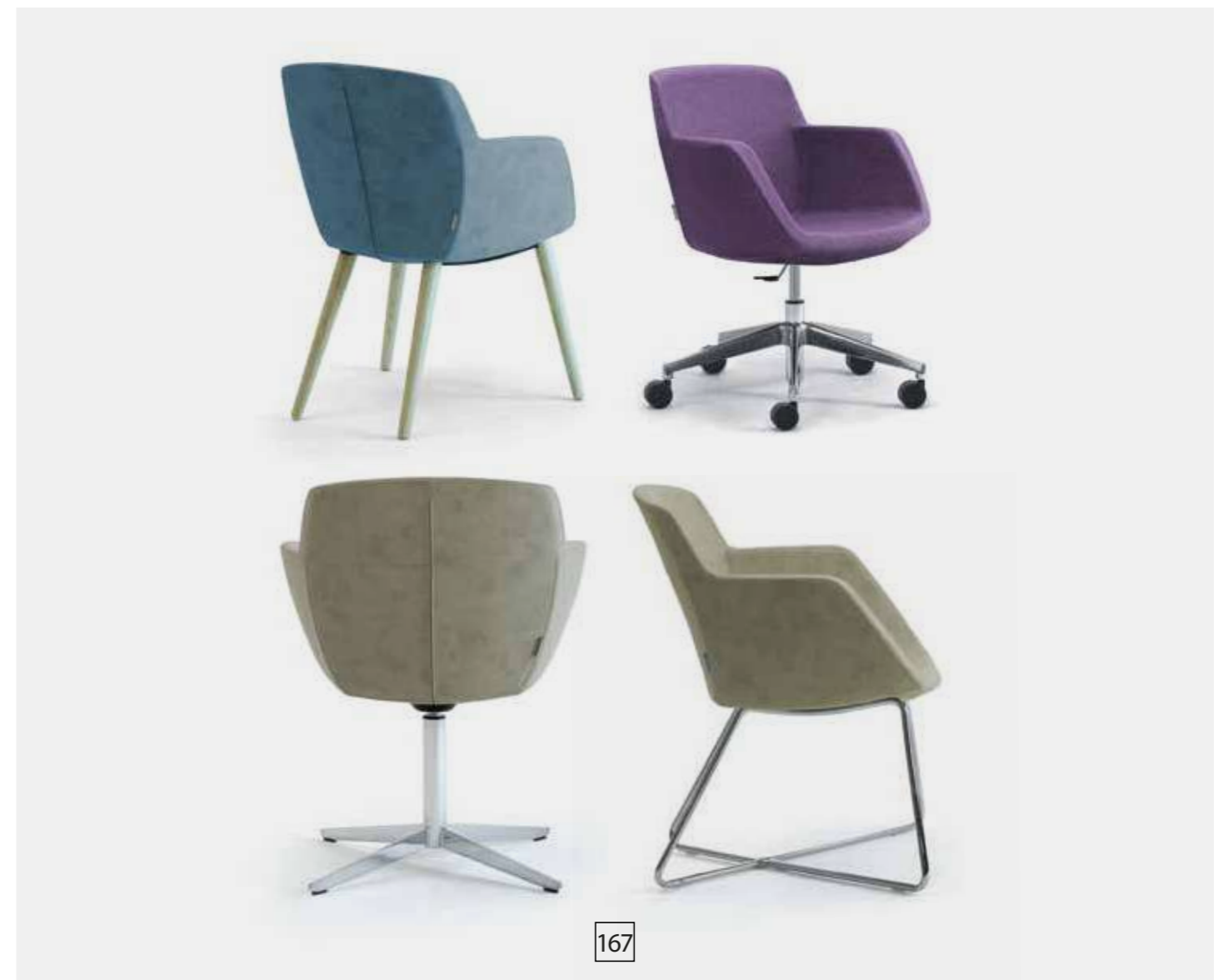

167



Rivestimento in lana bicolore, telaio in acciaio cromato  
 Wool upholstery two-tone, chromed steel frame  
 Revêtement en laine bicolore, structure en acier chromé  
 Stoffbezug aus Wolle zweifarbig, Gestell aus verchromtem Stahl

**SCHIENALE**  
 backrest / dossier / Rückenlehne



**BASAMENTI**  
 bases / piétements / Fussgestelle



**ACCESSORI**  
 accessories / accessoires / Zubehör



168

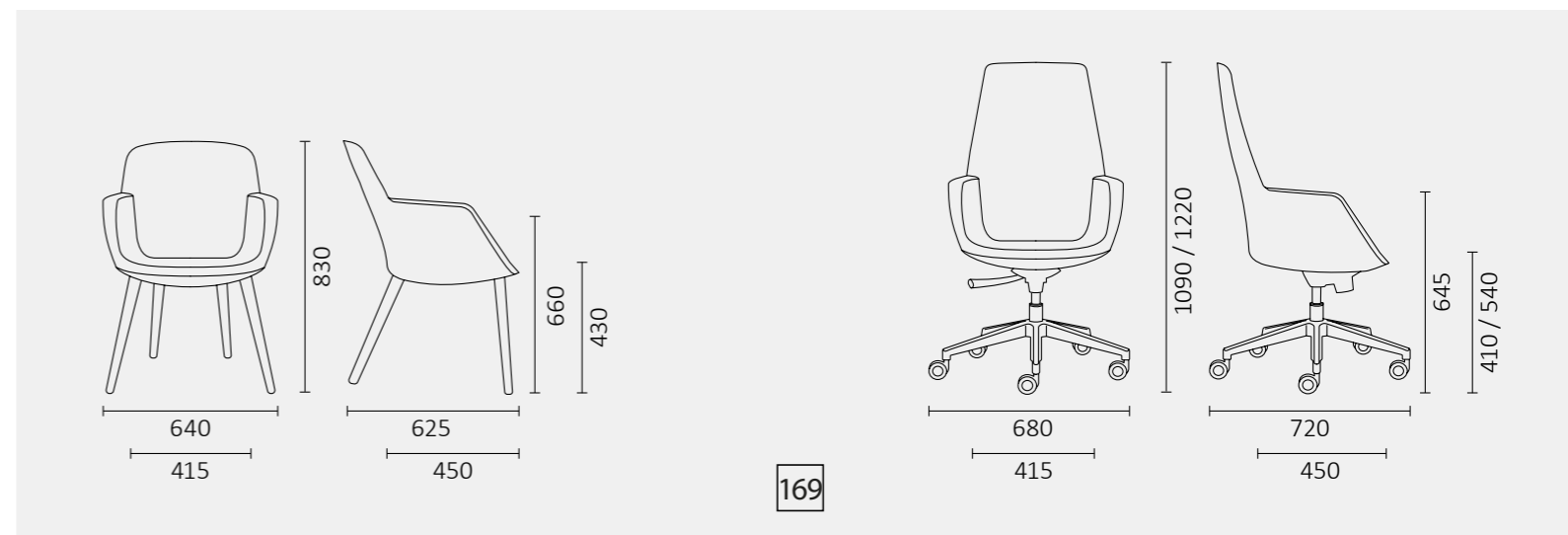

169

## aura | Trevor Hollard



Elegante meccanica a scomparsa. Retroschienale completamente imbottito con poggiaerani regolabile. Sottile bracciolo dal design unico. Sono solo alcune caratteristiche di Aura, che portano l'esperienza lavorativa su un altro livello. Tre differenti altezze dello schienale le permettono di adattarsi alle esigenze di ogni utente.

Elegant hidden mechanism. Fully padded backrest with adjustable lumbar support. Slim armrest with a unique design. These are just a few features of Aura that elevate the work experience to another level. Three different backrest heights allow it to adapt to the needs of every user.

Mécanisme élégant intégré. Dossier entièrement rembourré avec support lombaire réglable. Accoudoir fin au design unique. Ce ne sont que quelques-unes des caractéristiques d'Aura, qui élèvent l'expérience de travail à un niveau supérieur. Trois hauteurs de dossier différentes permettent de s'adapter aux besoins de chaque utilisateur.

Elegante integrata Synchronmechanik. Vollständig gepolsterte Rückenlehne mit verstellbarer Lordosenstütze. Schlanke und einzigartige Designarmlehne. Dies sind nur einige der Merkmale von Aura, die das Arbeitserlebnis auf eine neue Ebene heben. Drei verschiedene Rückenlehnenhöhen ermöglichen die Anpassung an die Bedürfnisse jedes Benutzers.









Schienale imbottito e rivestito, braccioli fissi  
 Padded and upholstered backrest, fixed armrests  
 Dossier rembourré et tapissé, accoudoirs fixes  
 Gepolsterte Rückenlehne, fixe Armlehnen



174



**SCHIENALE**  
 backrest / dossier / Rückenlehne



**BASAMENTI**  
 bases / piétements / Fussgestelle

**COLORI PLASTICHE**  
 plastic colours / couleurs plastique / Kunststofffarben

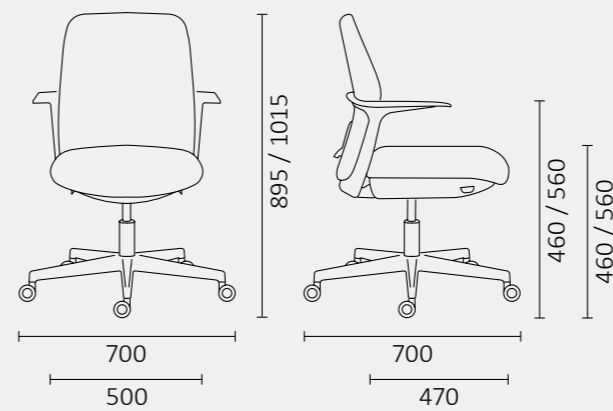

175

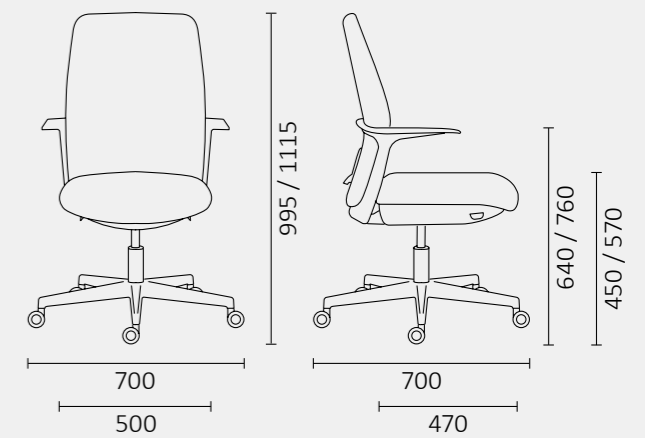

## wave | Stefano Sandonà e Sabrina Bettini



Stile e distinzione. Il vero cavallo di battaglia delle sedute direzionali. Un concentrato di tecnica, estetica e produttività garantisce a Wave di non passare mai inosservata. Disponibile in due diverse altezze, è la vera protagonista dell'ambiente office, sapientemente studiata e promossa per il suo design. Unico.

Style & class. The true strong point in executive seating: Wave. A concentrate of technique, aesthetic and productivity. Impossible to ignore it. The real protagonist of the workspace, nicely conceived and successful thanks to its timeless design. Simply... unique.

Style et distinction. Le véritable cheval de bataille des sièges de direction. Perfection technique, séduction des lignes et fonctionnalité sont toutes concentrées dans ce fauteuil. Wave : impossible de passer inaperçue! Véritable protagoniste du bureau, bien étudiée et digne de promotion par son design distingué. Tout simplement... unique.

Stil und Eleganz. Ein echtes Spitzenmodell unter den Chefsesseln mit Halbhochlehner. Ein Konzentrat an Technik, Optik und Produktivität macht Wave zu einem echten Blickfang. Erhältlich in zwei verschiedenen Höhen ist er der Star im Büro, der sorgfältig entwickelt wurde und ein außergewöhnliches Design besitzt. Einzigartig.





Rivestimento in pelle bicolore, base girevole in alluminio  
 Leather upholstery two-tone, swivel base in aluminium  
 Revêtement en cuir bicolore, piétement en aluminium poli  
 Lederbezug zweifarbig, Fusskreuz aus Aluminium

178

**SCHIENALE**  
 backrest / dossier / Rückenlehne



**BRACCIOLI**  
 armrests / accoudoirs / Armlehnen

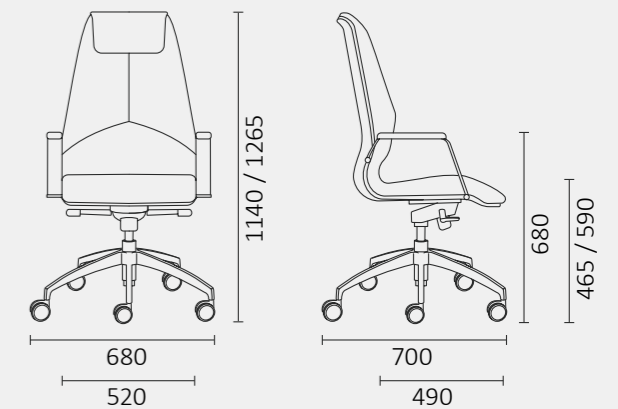
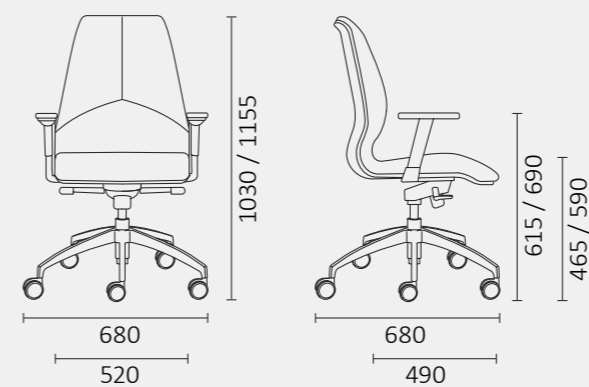

179

## zeus | *Stefano Sandonà e Sabrina Bettini*



Il perfetto connubio tra raffinatezza ed eleganza nelle forme. Una seduta quasi scultorea e ricca di personalità che si fa notare per la sua presenza importante. Zeus, grazie al nuovo rivestimento a cuciture si afferma come la seduta con più carattere della nostra già ricca collezione.

Zeus, a seductive and elegant executive chair, like a throne thanks to its sculptural lines and its optional quilted cover. The most personality-filled chair of our collection.

Style raffiné et élégance dans ce trône riche de caractère. Zeus, grâce à son revêtement optionnel capitonné, est le siège le plus important de notre collection.

Die perfekte Verbindung von Raffinesse und Eleganz bei den Formen. Ein Stuhl mit viel Persönlichkeit, der schon fast eine Skulptur ist und durch seine starke Optik auffällt. Zeus ist dank des neuen optionellen Bezugs mit Rautennähten der Stuhl mit dem meisten Charakter unserer schon reichhaltigen Kollektion.





Dettaglio schienale, rivestimento in pelle  
 Backrest detail, leather upholstery  
 Détail du dossier, revêtement en cuir  
 Detail der Rückenlehne, Lederbezug

**SCHIENALE**  
 backrest / dossier / Rückenlehne



**PERSONALIZZAZIONI**  
 customizations / personnalisations / Anpassungen



182

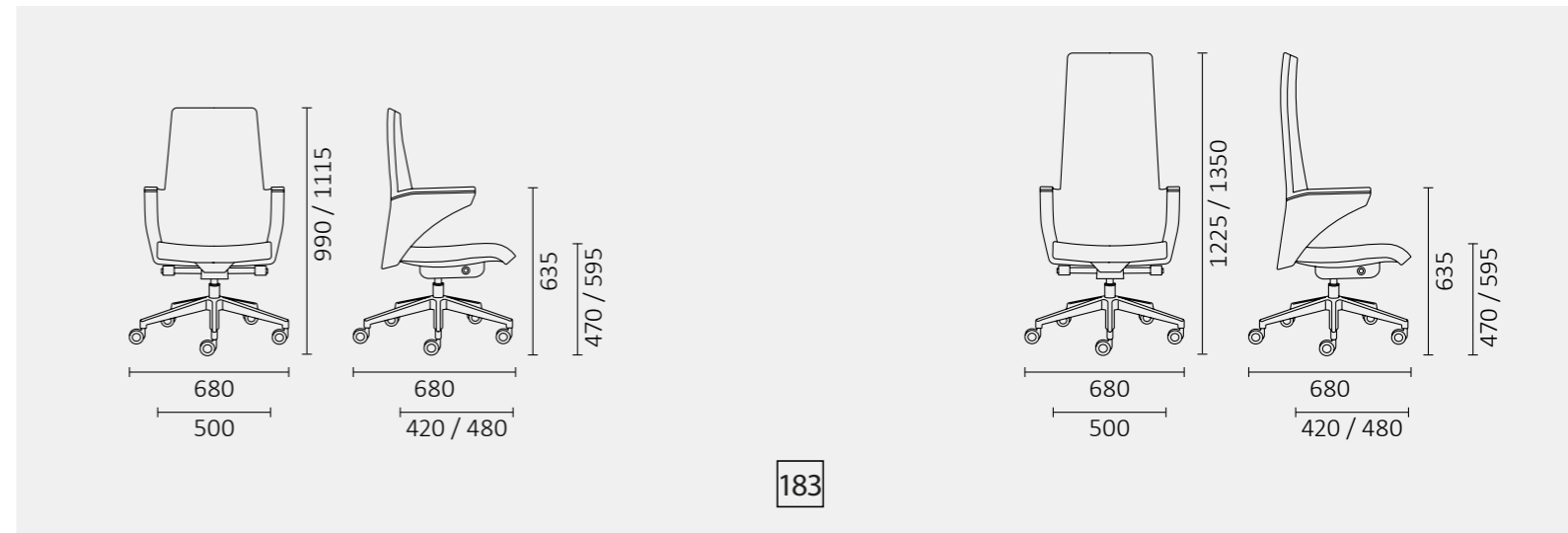

183

## origami | R&d Leyform



Come una sottile lama, Origami prende la forma del corpo, e come tutta la serie propone diversi meccanismi che permettono di personalizzare il proprio modo di rimanere seduti, lavorare, produrre. Personalizzata con cuciture su sedile e schienale: il tratto distintivo nell'estetica di questa seduta.

Introducing Origami, an ergonomic and sinuous chair with a classic but always contemporary design. It offers several adjustable options and customizable features to furnish your workspace as you prefer. Its distinguishing feature? The aesthetic.

Origami, son châssis est une lame qui suit la ligne du corps. Comme toute la collection Origami, aussi ce siège est équipé par des mécanismes qui vous permettront de personnaliser votre assise et votre travail. La force de l'esthétique.

Wie ein dünnes Blatt, das die Form des Körpers annimmt, Origami präsentiert auch, wie die gesamte Serie, drei verschiedene Mechanismen, die es ermöglichen, individuell zu gestalten, wie man sitzt, arbeitet und produktiv ist. Personalisiert mit Nähten auf Sitz und Rückenlehne: die Charakteristik dieses Stuhls.







Rivestimento in lana, telaio in acciaio verniciato nero  
 Wool upholstery, black painted steel frame  
 Revêtement en laine, structure en acier peint noir  
 Stoffbezug aus Wolle, Gestell aus schwarz lackiertem Stahl



Rivestimento in pelle, telaio in acciaio cromato  
 Leather upholstery, chromed steel frame  
 Revêtement en cuir, structure en acier chromé  
 Lederbezug, Gestell aus verchromtem Stahl

188



189





Rivestimento in pelle, telaio in acciaio verniciato nero  
Leather upholstery, black painted steel frame  
Revêtement en cuir, structure en acier peint noir  
Lederbezug, Gestell aus schwarz lackiertem Stahl



190



191



Schienale in rete, telaio in acciaio cromato  
 Mesh backrest, chromed steel frame  
 Dossier en résille, structure en acier chromé  
 Netzrückenlehne, Gestell aus verchromtem Stahl

192



**VERSIONE CON CUSCINO**

version with cushion / version avec coussin / Version Polsterkissen



**VERSIONE IMBOTTITA**

padded version / version tapissée / Version gepolstert



**VERSIONE IN RETE**

mesh version / version en résille / Version mit Netzrücken



**BRACCIOLI**

armrests / accoudoirs / Armlehnen



**COLORE TELAIO**

frame colors / couleurs du cadre / Gestellfarben

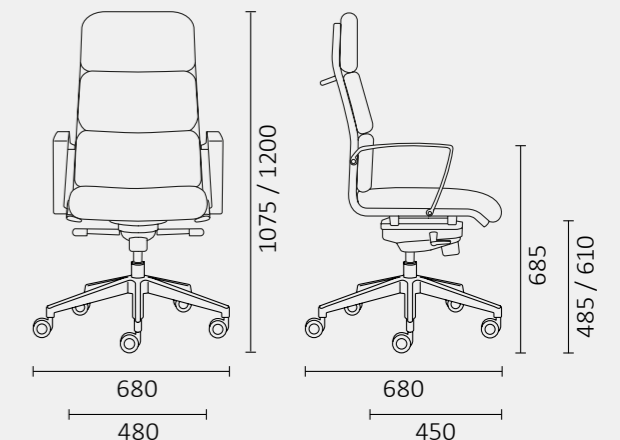
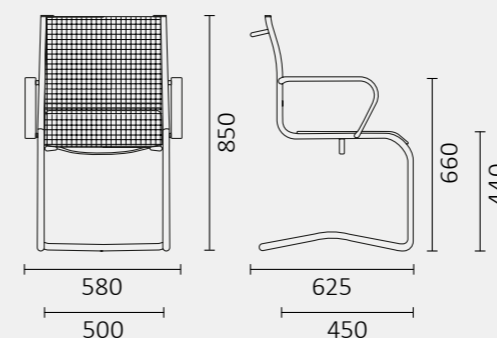

193

# elegance | R&d Leyform



Il bracciolo è un vero elemento di classe ed eleganza, che fa risaltare il contrasto delle cromature con il morbido rivestimento. Lo schienale ondulado nella parte alta descrive perfettamente l'anima di questa poltrona. Elegance completa lo spazio lavorativo donando un tocco di raffinatezza alla stanza.

Elegance, a classic taste in the contemporary lifestyle. Its upholstered armrest contrasting with the chrome frame and its ergonomic backrest wavy on the top, make this chair so elegant and give refinement to workspace. Class & Style.

Style et design pour ces accoudoirs rembourrés avec une lame chromé en contraste. Grace à la ligne sinieuse de son dossier ondulé, Elegance ameuble l'espace avec goût en donnant une touche souple à l'espace de travail.

Die Armlehne ist ein Element, das Klasse und Eleganz ausstrahlt und den Kontrast von Verchromungen und weichem Bezug hervorhebt. Die im oberen Bereich gewellte Rückenlehne beschreibt perfekt die Seele dieses Stuhls. Elegance für den Arbeitsplatz und das gewisse Etwas für den Raum.



Rivestimento in ecopelle, telaio in acciaio cromato  
Eco-leather upholstery, chromed steel frame  
Revêtement en simili cuir, structure en acier chromé  
Kunstlederbezug, Gestell aus verchromtem Stahl

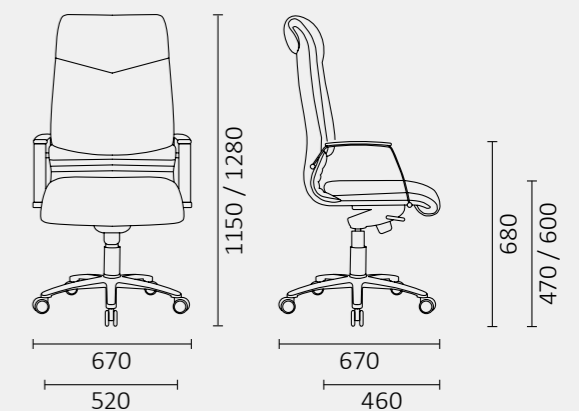
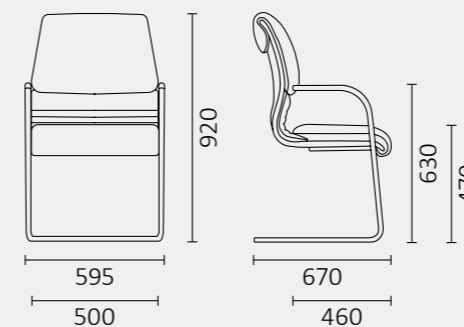

Rivestimento in pelle,  
telaio in acciaio cromato  
Leather upholstery,  
chromed steel frame  
Revêtement en cuir,  
structure en acier chromé  
Lederbezug, Gestell  
aus verchromtem Stahl

## doge | R&d Leyform



Una seduta maestosa, che ci permette di fare un salto indietro nel tempo, con un prodotto praticamente perfetto per chi ricerca solidità ed eleganza al tempo stesso. Un basamento robusto, una meccanica regolabile, tutto contribuisce a rendere Doge Lux la regina delle sedie classiche direzionali.

Doge Lux, the king of all classical chairs. The elegant design across the technical excellence, furnishing any presidential environment. High-class executive environment. Extremely comfortable.

Apprêtez vous à replonger dans le passé: nous avons le plaisir de vous présenter Doge Lux, le roi des fauteuils classiques. Si vous cherchez solidité, confort et élégance, voilà la réponse à vos exigences.

Ein majestätischer Stuhl, der es uns erlaubt, einen Zeitsprung in die Vergangenheit zu machen mit einem praktisch perfekten Produkt für all jene, die gleichzeitig Robustheit und Eleganz suchen. Ein solides Fußgestell, ein verstellbarer Mechanismus, alles trägt dazu bei, Doge Lux zum König der klassischen Chefsessel mit Halbhochlehner zu machen.

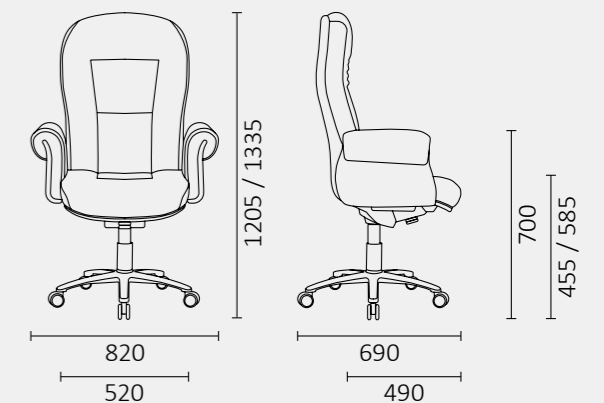

# sgabelli | *Leyform*



samba | 200



zerosedici | 204



punto | 208



my stool | 210



ocean | 212



iLike | 214



twist | 216



officia | 220



saloon | 222



laMia | 224



sprint | 226



# samba | *Stefano Sandonà e Sabrina Bettini*



Ben due varianti nel basamento, una comoda seduta con imbottitura in poliuretano schiumato, e il design inconfondibile di Samba. La versione Stool stupisce per la sua eleganza, minimale e moderna, semplicemente perfetta per il contract, sorprendentemente adattabile in ambiente domestico.

Two base options, a comfortable seat thanks to its cold injected foam upholstery and the unmistakable design of Samba. The stool option just surprises for its minimalist and contemporary elegance, simply perfect for the contract world, amazingly suitable for residential areas, as well.

Deux options de piètement, une assise 'confort' avec un rembourrage ferme en mousse injectée et le design incomparable de « Samba ». La version « Stool » suprenne pour son élégance minimaliste et contemporaine, simplement parfaite pour le secteur « Contract », étonnement adaptable à l'habitat aussi.

Zwei Optionen von Untergestelle, eine komfortable Schale aus Kaltschaum und das unverwechselbare Design Samba. Der Hocker überrascht durch seine minimale und modern Eleganz, einfach perfekt für den Objektbereich, und Anpassungsfähig im Homebereich.





Monoscocca imbottita e rivestita, base 4 gambe legno  
 Padded and upholstered shell, base with 4 wooden legs  
 Monocoque rembourré et tapissée, piètement 4 pieds en bois  
 Gepolsterter Formschalenstuhl, 4-Fussholzgestell

202



**BASAMENTI**  
 bases / piétements / Fussgestelle



**SEDUTA**  
 seat / séance / Sitz



**VERNICIATURA**  
 painting / peinture / Lackierung

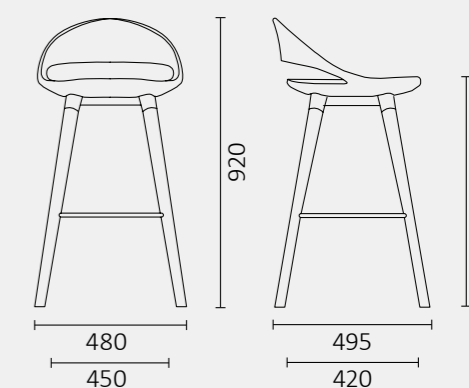
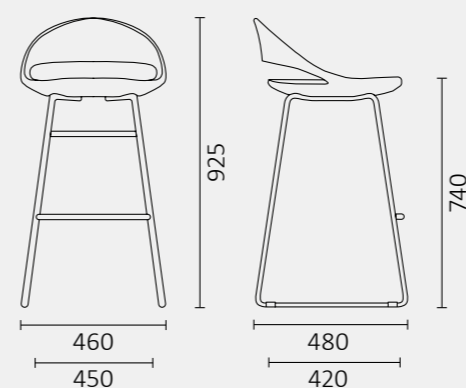

203

## zerosedici | *Simone Bolzan*



Uno sgabello impilabile, dalla linea moderna, con un rivestimento personalizzabile, e facile da usare? Zerosedici stool è perfetto per completare un ambiente arredato con la famiglia Zerosedici. Lasciatevi ispirare dal colore dei telai, e gioca utilizzando tutte le combinazioni di colore disponibili.

Are you looking for a stackable stool with modern design, customizable upholstery and easy to use? Zerosedici stool is the one for you, perfect to combine with other models of Zerosedici collection. Be inspired by the frame colours and play with all the available upholstery combinations.

Un tabouret empilable au design moderne avec un revêtement individualisable et d'utilisation simple? Zerosedici Stool est parfait pour parfaire des espaces déjà décorés par la collection Zerosedici. Laissez-vous inspirer par les multiples combinaisons de couleurs des structures et revêtements!

Ein stapelbarer Hocker, modern, funktionell und mit einem individuellen Bezug? Zerosedici Hocker ist perfekt um die ursprüngliche Familie zu vervollständigen. Lassen Sie sich von den verschiedenen Gestellfarben und von den vielfachen Bezugskombinationen inspirieren.







Monoscocca imbottita e rivestita, Telaio in acciaio verniciato  
 Padded and upholstered shell, painted steel frame  
 Monocoque rembourré et tapissée, Structure en acier peint  
 Gepolsterter Formschalenstuhl, Gestell aus lackiertem Stahl

206

**SEDUTA**  
 seat / séance / Sitz



**FINITURE TELAIO**  
 frame finishes / finitions châssis / Gestellausführung

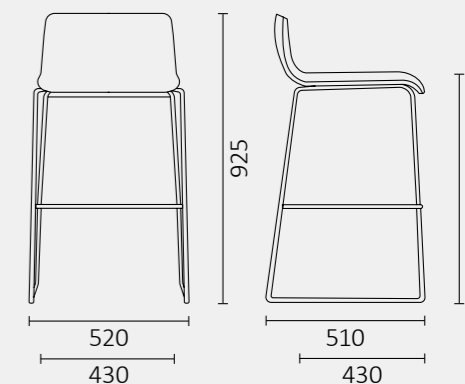
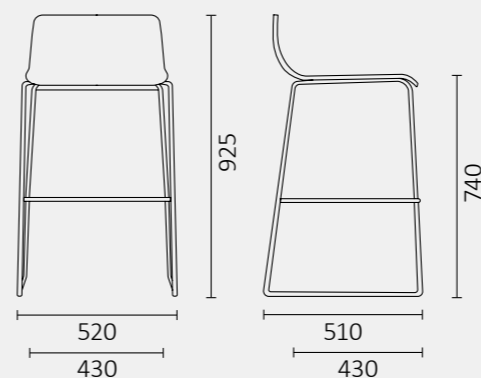

207

# punto | R&d Leyform



Comodità e facilità d'uso si legano perfettamente in questo sgabello, il tutto unito da una solida struttura cromata che ne esalta la linea contemporanea. Punto offre molteplici configurazioni diverse tra basamento e seduta per un elemento semplice che contribuisce a dare un tocco di colore alla stanza.

Punto model stool, with a metal frame highlighting its modern design, it is a comfortable, practical and dynamic element thanks to its different configurations. Suitable for a modern space, choose it in the finish you prefer.

Design contemporain grace à son chassis chromé: Punto, le tabouret dans lequel s'épousent confort et praticité. Personnalisable dans beaucoup de configurations possibles, il est parfait pour colorer tous les espaces.

Komfort und Benutzungsfreundlichkeit verbinden sich bei diesem Barhocker perfekt, alles vereint mit einem soliden verchromten Gestell, das die moderne Linie unterstreicht. Punto bietet zahlreiche unterschiedliche Fußgestell- und Sitzkonfigurationen für ein schlichtes Element, das Farbe in den Raum bringt.



Seduta imbottita e rivestita, sedile girevole regolabile in altezza  
Padded and upholstered seat, height-adjustable swivel seat  
Assise rembourrée et tapissée, siège giratoire réglable en hauteur  
Gepolsterter Sitz, Drehsitz in Höhe verstellbar

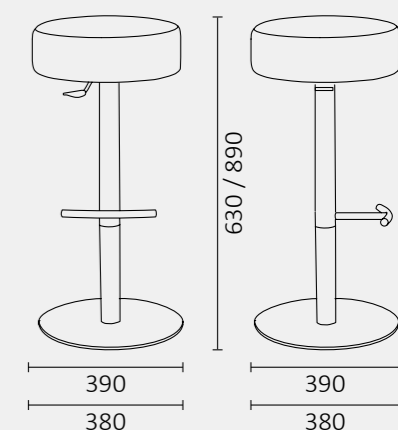
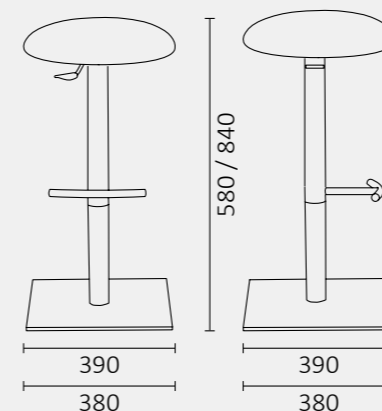

Monoscocca in legno curvato,  
 telaio in acciaio cromato  
 Wood curved multilayer shell,  
 chromed steel frame  
 Contreplaqué moulé,  
 structure en acier chromé  
 Formschalenstuhl aus Buche,  
 Gestell aus verchromtem Stahl

## my stool | R&d Leyform



In cucina come al bar, My Stool arreda con un tocco di design lo spazio circostante. Un pratico sgabello facilmente impilabile, con tre differenti basamenti e due sedute, elemento di arredo che non passa inosservato grazie alla sua forma accattivante e sempre attuale.

My stool is a very versatile model with different bases and seats, ideal for bars or modern kitchen. A dynamic and comfortable stool, it becomes the protagonist of the space at home or in bars furnishing the space with style and design.

Au bistrot comme à la maison... My Stool meuble son milieu avec style. Ce tabouret hors du temps s'intègre parfaitement dans l'espace grâce à la variété des configurations possibles, à sa praticité et à son design.

In der Küche wie in der Bar richtet My Stool den Raum stylish ein. Ein praktischer Barhocker, der leicht gestapelt werden kann, mit drei unterschiedlichen Fußgestellen und zwei Sitzen – ein Einrichtungselement, das dank seiner attraktiven und immer aktuellen Form ein echter Eyecatcher ist.

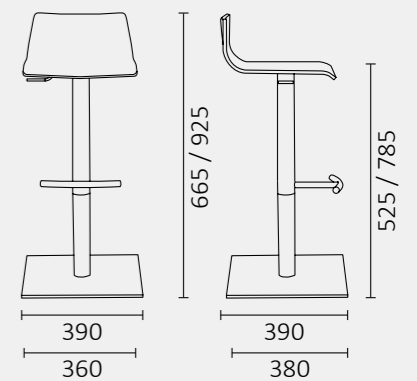
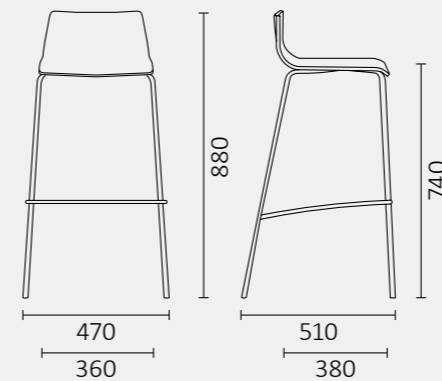

# ocean | *Stefano Sandonà e Sabrina Bettini*



Sgabello dalle linee stilizzate e decise. Ocean esalta la stessa ergonomia della sedia, ma con una linea decisamente più slanciata. Arreda con stile, e gioca con gli accostamenti cromatici, permettendoti di mescolare i colori di tessuto e plastica nel modo che più ti rappresenta.

Stool with stylized and bold lines. Ocean enhances the same ergonomics as the chair but with a much more streamlined look. Furnish with style and play with color combinations, allowing you to mix fabric and plastic colors in a way that represents you best.

Un tabouret aux lignes stylisées et marquées. Ocean offre la même ergonomie que la chaise, mais avec une ligne résolument plus élancée. Jouez avec les combinaisons de couleurs, en mélangeant les couleurs du tissu et du plastique de la manière qui vous représente le mieux pour meubler avec style.

Ein Hocker mit starken, stilisierten Linien. Ocean bietet die gleiche Ergonomie wie der Stuhl, aber mit einer deutlich schlankeren Linie. Er ist ein stilvolles Möbelstück, das mit Farbkombinationen spielt und Ihnen erlaubt, die Farben von Stoff und Kunststoff so zu mischen, wie es Ihnen am besten gefällt.



Sedile e schienale in polipropilene, telaio verniciato in tinta  
Polypropylene seat and backrest, frame painted in the same color  
Assise et dossier en polypropylène, châssis peint dans le même coloris  
Sitz und Rückenlehne aus Kunststoff, Gestell in der gleichen Farbe lackiert

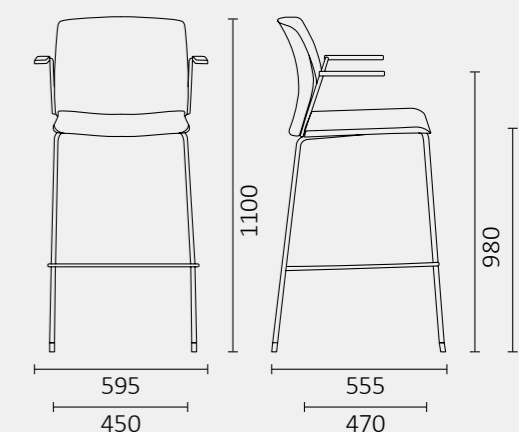

## iLike | R&d Leyform



Una seduta generosa, lo schienale rialzato, la possibilità di avere il pannello sul sedile o sullo schienale rendono iLike sgabello perfetto per arredare lo spazio domestico, strizzando però l'occhio anche all'ufficio o gli ambienti pubblici. Completamente personalizzabile come gli altri articoli della famiglia.

A comfortable seat, raised backrest, the option to have the panel on the seat or backrest make iLike stool perfect for furnishing home spaces, also catering to offices or public environments. Completely customizable like other items in the product family.

Une assise généreuse, un dossier renforcé, la possibilité d'avoir le panneau sur l'assise ou sur le dossier font du tabouret iLike un objet parfait pour meubler l'espace domestique, tout en faisant un clin d'œil au bureau ou à l'environnement public. Entièrement personnalisable comme les autres articles de la famille.

Eine grosszügige Hocker, eine erhöhte Rückenlehne und die Möglichkeit, gepolsterte Sitz- und Rückenauflagen anzubringen, machen iLike zu einem perfekten Hocker für die Einrichtung des Hausbereichs, aber auch mit einem Blick für das Büro oder öffentliche Bereiche. Völlig individuell gestaltbar wie die anderen Artikel der Familie.

Sedile e schienale in polipropilene,  
base a slitta  
Polypropylene seat and backrest,  
sled base  
Assise et dossier en polypropylène,  
piètement luge  
Sitz und Rückenlehne aus Kunststoff,  
Freischwingergestell

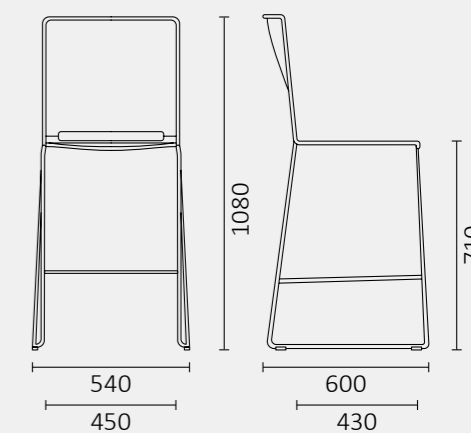

## twist | Scagnellato / Ferrarese e Bertolini



Lo sgabello più divertente e brioso. Vi presentiamo Twist, un elemento imprevedibile che spezza l'uniformità degli spazi e regala nuove situazioni di impiego. Un arredo versatile, disponibile anche con pad in morbido PU, da usare dove il contesto prevede un approccio veloce e dinamico.

The most fun and lively stool. Introducing Twist, an unpredictable element that breaks the uniformity of spaces and provides new usage situations. A versatile piece of furniture, available also in soft pad PU, to be used where the context requires a fast and dynamic approach.

Le tabouret le plus sympathique et le plus original. Nous présentons Twist, un élément imprévisible qui rompt l'uniformité des espaces et offre de nouvelles situations d'utilisation. Un meuble polyvalent, disponible aussi avec placet en PU, à utiliser là où le contexte exige une approche rapide et dynamique.

Der sympathische und lebendigste Hocker. Wir präsentieren Twist, ein unberraschendes Element, das die Gleichförmigkeit von Räumen aufbricht und neue Nutzungssituationen bietet. Ein vielseitiges Möbelstück, auch mit einem weichem PU Pad erhältlich, der überall dort zum Einsatz kommt, wo der Kontext einen schnellen und dynamischen Ansatz erfordert.





**ALTEZZA**  
height / hauteur / Höhe



**COLORI PLASTICHE**  
plastic colours / couleurs plastique / Kunststofffarben



Sgabello regolabile in altezza, rivestimento in tessuto  
Height-adjustable stool, fabric upholstery  
Tabouret réglable en hauteur, revêtement en tissu  
Höhenverstellbarer Hocker, Stoffbezug

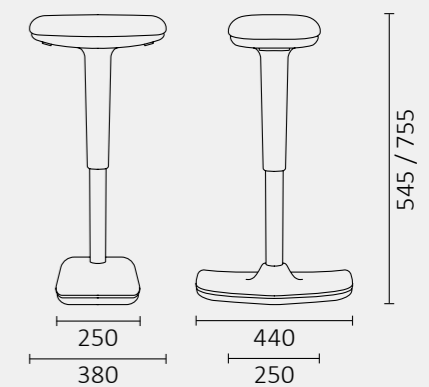

# officia | *R&d Leyform*



Un semplice sgabello, ma con caratteristiche tecniche complete. Officia è una seduta robusta ed efficace, con una straordinaria escursione nell'elevazione a gas, una morbida seduta e schienale in PU e un comodo e pratico anello poggiapiedi. L'indispensabile per migliorare il comfort nelle aree dalla grande produttività.

A simple work stool though with complete technical features. Officia is a sturdy and performing chair, featuring a remarkably wide height adjustment, a soft PU comfortable seat and a functional footrest ring. A "must" to improve the comfort in high productivity working spaces.

Un tabouret simple pourtant avec des caractéristiques techniques complètes. Officia est un siège robuste et performant avec une élévation en hauteur qui sort de l'ordinaire, avec une assise et dossier souples en PU et un repose-pied fonctionnel et confortable. L'indispensable pour améliorer le confort dans les espaces de forte productivité.

Ein einfacher aber technisch kompletter Arbeitshocker. Officia ist ein robuster und leistungsfähiger Stuhl, mit einer außergewöhnlich breiter Höhenverstellung, mit Sitz und Rückenlehne aus weichem PU-Schaum und mit einem funktionsfähigen und komfortablen Fußring ausgestattet. Ein Must um den Komfort in grosse Produktivitätsräume zu erhöhen.



Sedile e schienale in PU,  
sedile girevole regolabile in altezza  
PU seat and backrest,  
height-adjustable swivel seat  
Assise et dossier en PU,  
siège giratoire réglable en hauteur  
Sitz und Rückenlehne aus PU,  
Drehstuhl in Höhe verstellbar

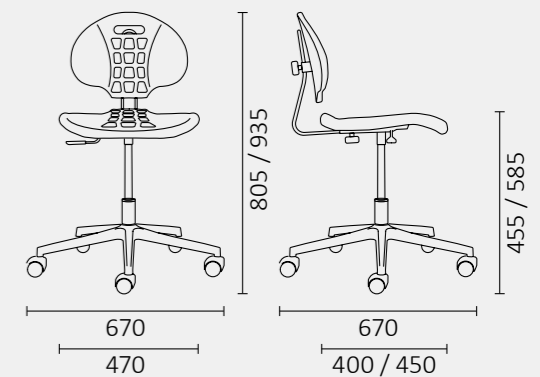
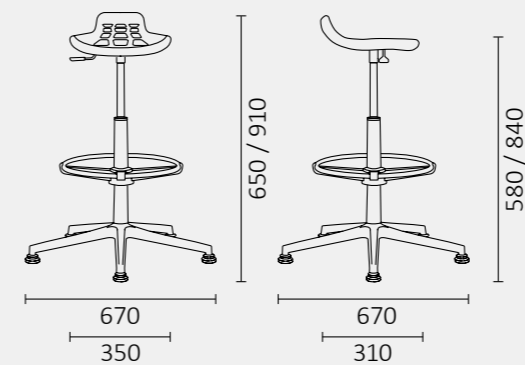



Imbottitura in tessuto,  
 piedini in nylon nero  
 Upholstery in fabric,  
 feet in black nylon  
 Revêtement en tissu,  
 pieds en nylon noir  
 Polsterung aus Stoff,  
 Füße aus schwarzem Nylon

## saloon | R&d Leyform



Sedia operativa da banco o semplice sgabello per un utilizzo lavorativo, Saloon è un elemento ridotto all'essenziale: basamento e seduta, con il poggipiedi disponibile nella versione più alta. Lo schienale e i braccioli fissi o regolabili infine completano la versione più accessoriata.

Saloon, the ideal stool to furnish your workspace or your dining room with a minimal design. It is available in various colours and finishes as footrest, backrest and armrest which make the chair very comfortable.

Siege de travail ou tabouret? Saloon: compacte, minimal, personnalisable... transformable, sa ligne essentielle se complète avec dossier, accoudoir et repose pieds. Quest ce que vous cherchez?

Arbeitsdrehstuhl oder einfacher Hocker für eine Benutzung bei der beruflichen Tätigkeit. Saloon ist ein minimalistisches Element: Fußgestell und Sitz, mit Fußauflage bei der höheren Ausführung. Die Rückenlehne und die fixen Armlehnen vervollständigen die zubehörreichste Ausführung.

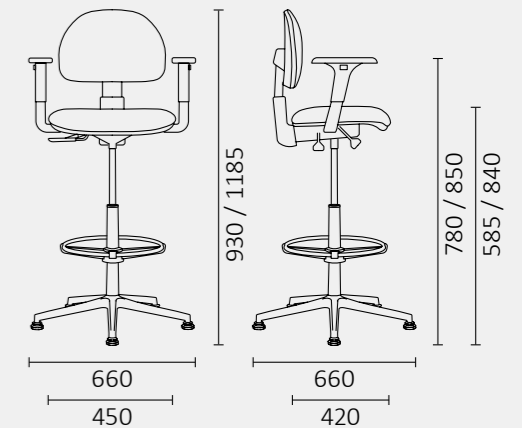
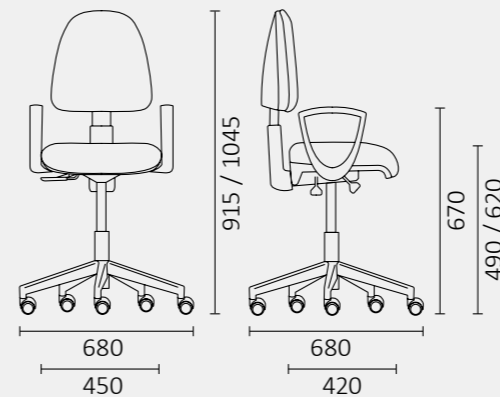

## laMia | R&d Leyform



Disponibile in lamiera, polipropilene o legno, grazie alla facile regolazione in altezza, al comodo anello poggiatesta e al sicuro basamento a cinque razze, LaMia sgabello è quasi un'estensione di una seduta ufficio, particolarmente adatta e facilmente utilizzabile proprio in un ambiente produttivo.

Available in metal perforated plate, polypropylene or wood, thanks to its easy height adjustment, its comfortable footrest and its stable 5 star base, laMia stool is like a natural extension of an office seat, perfect and easy to be placed in a productive environment.

Disponibile en tôle, Polypro ou bois, La Mia tabouret représente presque une extension d'un siège de bureau grâce à son simple réglage en hauteur, au fonctionnel repose-pieds, à la sécurité de son piétement, ce qui le rend particulièrement indiqué dans un environnement de travail.

Erhältlich in den Lochblech-, Polypropylen- und Holz Ausführungen, stellt der LaMia Hocker, dank der funktionellen Höhenverstellung, der bequemen Fußstütze und dem hochwertigen Fußkreuz wirklich eine Erweiterung eines Bürostuhls dar. Er eignet sich eigentlich besonders gut in produktive Umgebungen.



Sedile e schienale in polipropilene, sedile girevole regolabile in altezza  
Polypropylene seat and backrest, height-adjustable swivel seat  
Assise et dossier en polypropylène, Siège giratoire réglable en hauteur  
Sitz und Rückenlehne aus Kunststoff, Drehsitz in Höhe verstellbar

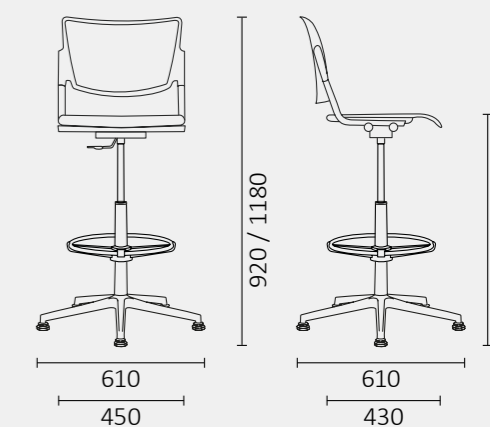

# sprint | R&d Leyform



Pratico e semplice nel suo utilizzo, Sprint Stool è uno sgabello solido e robusto. In ambito lavorativo è insostituibile, specialmente quando c'è bisogno di uno sgabello regolabile e comodo per un utilizzo prolungato.

Practical and simple in its use, Sprint Stool is a sturdy and sturdy stool. In the workplace it is irreplaceable, especially when there is a need for an adjustable and comfortable stool for prolonged use.

Pratique et simple dans son utilisation, Sprint Stool est un tabouret robuste et robuste. Sur le lieu de travail, il est irremplaçable, en particulier lorsqu'un siège réglable et confortable est nécessaire pour une utilisation prolongée.

Praktisch und einfach in seiner Verwendung ist Sprint Hocker ein robuster und robuster Hocker. Am Arbeitsplatz ist es unersetzbar, vor allem wenn ein verstellbarer und bequemer Sitz für längere Zeit benötigt wird.



Rivestimento in tessuto,  
base girevole in nylon nero  
Fabric upholstery,  
swivel base in black nylon  
Revêtement en tissu,  
Piètement en nylon noir  
Stoffbezug,  
Fusskreuz aus schwarzem Kunststoff

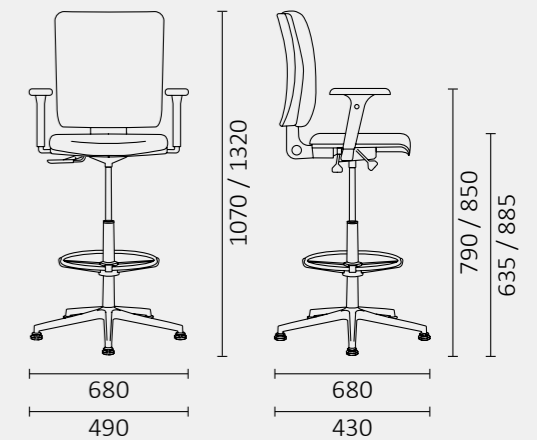

# collettività | *Leyform*



ocean | 230



iLike | 236



key ok | 240



cosmo | 244



ipa | 250



zerosedici | 254

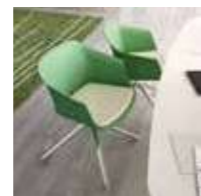

claire | 260



greta | 266



laMia | 270



cortina | 274



valeria | 278



laila | 282



spot | 284



gardena | 286



cristallo | 288



arcade | 290



panche | 292

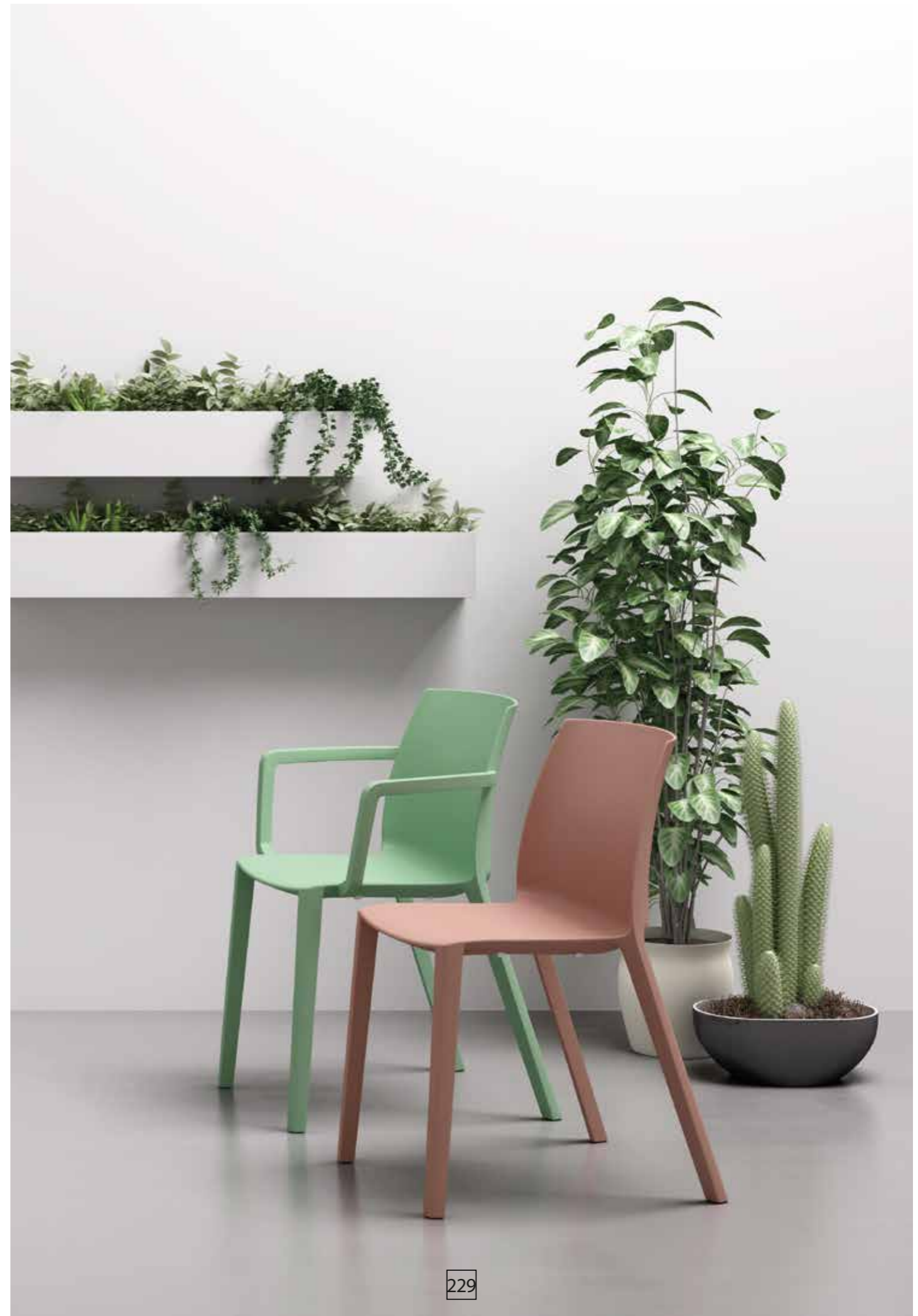

## ocean | *Stefano Sandonà e Sabrina Bettini*



Una linea giovane, fresca e minimale. Ocean si esalta nelle forme leggere e sottili, proponendo un'intera famiglia per destinazioni d'uso sempre diverse. Sedia, sgabello, seduta girevole o panca. Configura la tua seduta per assecondare nel modo migliore tutte le tue esigenze.

A young, fresh and minimal line. Ocean enhances itself in light and slim forms, offering a whole family for different purposes. Chair, stool, swivel chair or bench. Configure your chair to best suit all your needs.

Une ligne jeune, fraîche et minimaliste. Ocean s'exalte dans ses formes légères et subtiles, proposant toute une famille pour différents usages. Chaise, tabouret, fauteuil pivotant ou banc. Configurez votre siège pour répondre au mieux à tous vos besoins.

Eine frische und minimalistische Linie. Ocean zeichnet sich durch seine leichten und schlichte Formen aus und bietet eine komplette Familie für verschiedene Anwendungen. Stuhl, Hocker, Drehstuhl oder Traversenbank. Konfigurieren Sie Ihren Stuhl, damit er allen Bedürfnissen entsprechen kann.







Sedile e schienale in polipropilene,  
telaio verniciato in tinta  
Polypropylene seat and backrest,  
frame painted in the same color  
Assise et dossier en polypropylène,  
chassis peint dans le même coloris  
Sitz und Rückenlehne aus Kunststoff,  
Gestell in der gleichen Farbe lackiert

234

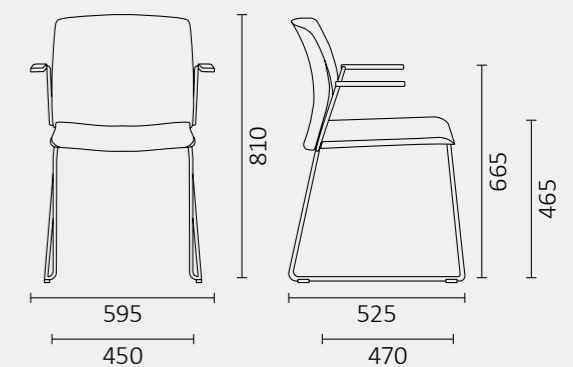
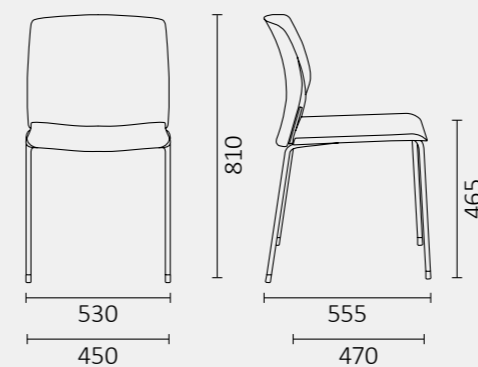

235

**BRACCIOLI**  
armrests / accoudoirs / Armlehnen



**BASAMENTI**  
bases / piétements / Fussgestelle



**COLORI PLASTICHE E TELAI**  
plastic and frame colours / couleurs plastique et châssis / Kunststoff- und Gestellfarben



**ACCESSORI**  
accessories / accessoires / Zubehör



## iLike | *R&d Leyform*



Design esile e minimale. Finiture cromate che fanno risaltare al massimo la seduta e l'avvolgente schienale. Comodità legata ad una struttura sottile ed estremamente tecnica. La facile impilabilità aiuta nel risparmio dello spazio in qualsiasi stanza e in ogni occasione. Esattamente come piace a me. i Like.

Minimal and light design for this chair. The metal frame highlights the seat and the ergonomic back. This chair is also easily stackable. Extreme contemporary thanks to its light and technological frame. Ilike. I like it.

Design exile et minimal, finitions chromées qui vont mettre en évidence l'assise et l'enveloppant dossier, confort extrême grâce à son châssis léger et technique. Ce fauteuil est aisément empilable et idéal pour chaque occasion. Je l'aime, iLike.

Schlankes und minimalistische Design. Verchromte Verarbeitungen, die den Sitz und die umhüllende Rückenlehne bestmöglich zur Geltung kommen lassen. Sitzkomfort dank eines dünnen und extrem technischen Gestells. Leicht zu stapeln und daher in jedem Raum und bei jedem Anlass platzsparend. Genau so wie es mir gefällt. Ilike.







**SCOCCA**  
shell / coque / Schale



**BRACCIOLI**  
armrests / accoudoirs / Armlehnen



**COLORI PLASTICHE E TELAI**  
plastic and frame colours / couleurs plastique et châssis / Kunststoff- und Gestellfarben

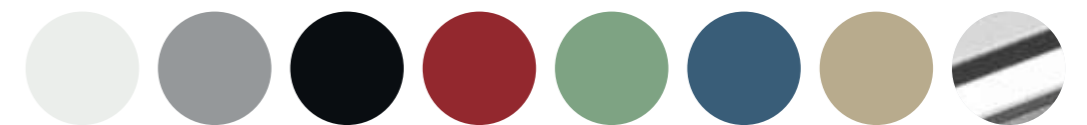

**ACCESSORI**  
accessories / accessoires / Zubehör



Sedile e schienale in polipropilene, base a slitta  
Polypropylene seat and backrest, sled base  
Assise et dossier en polypropylène, piètement luge  
Sitz und Rückenlehne aus Kunststoff, Freischwingergestell

238

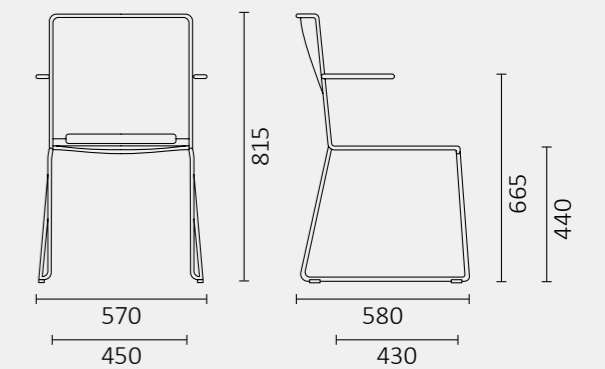
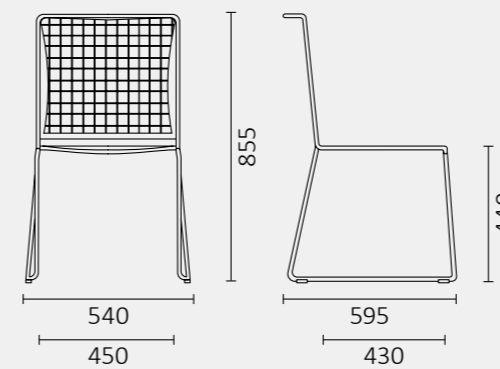

239

## key ok | R&d Leyform



Un prodotto dalle mille sfaccettature, configurabile a piacimento, tra seduta imbottita o in polipropilene, schienale in rete, ruote e tavoletta. Seduta reclinabile per essere riposta in grandi quantità utilizzando uno spazio ridottissimo. Key-ok, la sedia giusta sempre al posto giusto.

Key-ok, a stackable and customizable chair. Available with upholstered or polypropylene seat, breathable mesh back, castors and writing tablet. A dynamic and practical solution thanks to its optional tip-up seat... the right choice!

Key-ok, la chaise toujours au bon endroit, au bon moment, complètement personnalisable. Cette chaise a été conçue pour être rapidement empilable dans un petit espace grâce à son assise rabattable. Disponibles avec assise rembourrée ou en polypropylène, dossier résille, roulettes et tablette porte PC.

Ein Produkt in tausend Ausprägungen, das nach Wunsch mit einem Polstersitz oder einem Sitz aus Polypropylen, einer Rückenlehne aus Netz, Rollen und Schreibplatte zusammengestellt werden kann. Klappbarer Sitz, um auf kleinstem Raum bestmöglich untergebracht zu werden. Key-ok, der richtige Stuhl am richtigen Ort.





Schienale in rete, gambe in acciaio cromato  
 Mesh backrest, chromed steel legs  
 Dossier en résille, pieds en acier chromé  
 Netzurückenlehne, Füße aus verchromtem Stahl



242

**SEDUTA**  
 seat / assise / Sitz



**BRACCIOLI**  
 armrests / accoudoirs / Armlehnen



**COLORI PLASTICHE**  
 plastic colours / couleurs plastique / Kunststofffarben



**FINITURE TELAIO**  
 frame finishes / finitions châssis / Gestellausführung



**IMPILABILITÀ**  
 stackability / empilabilité / Stapelbarkeit

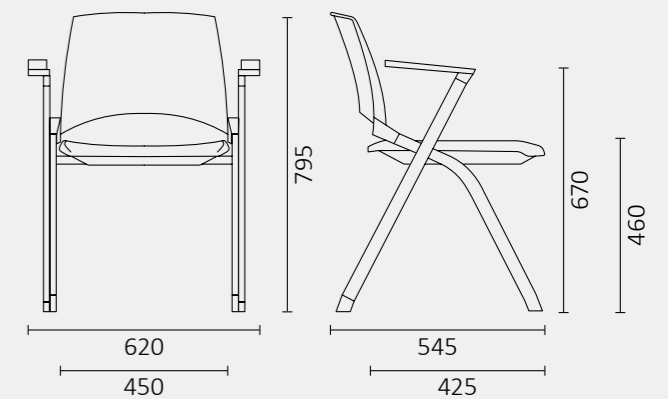

243

## cosmo | *Angelo Pinaffo*



Una pratica seduta per la collettività, disponibile nelle versioni quattro gambe, slitta e panca. La comodità viene garantita grazie alla perfetta inclinazione dello schienale e al comodo cuscino imbottito. Arredare con Cosmo è davvero semplice, grazie anche ai suoi colori moderni ed estremamente vivaci.

A functional chair for public spaces, available in different versions such as four legs, sled base and bench. The comfort is ensured by the perfect inclination of the back and by the soft seat pad. It is easy to find the right place for Cosmo, thanks to its modern and bright colours.

Un siège très fonctionnel pour la collectivité, disponibles dans les versions 4-pieds, luge e banquette. Le confort y est garanti grâce à une inclinaison impeccable du dossier et à l'agréable coussin rembourré. Décorer avec Cosmo est vraiment facile, grâce à ses couleurs modernes et extrêmement vifs.

Ein funktionsfähiger Besucherstuhl, erhältlich in den Versionen mit 4-Fuss, Freischwinger Traversenbank. Komfort ist dank der perfekten Neigung der Rückenlehne und dem bequemen Sitzkissen garantiert. Das Einrichten mit Cosmo ist aufgrund der modernen und äußerst lebendigen Farben sehr einfach.







**SCOCCA**  
shell / coque / Schale



**COLORI PLASTICHE**  
plastic colours / couleurs plastique / Kunststofffarben



**BASAMENTI**  
bases / piétements / Fussgestelle



**FINITURE**  
finishes / finitions / Gestellausführung



**IMPILABILITÀ**  
stackability / empilabilité / Stapelbarkeit

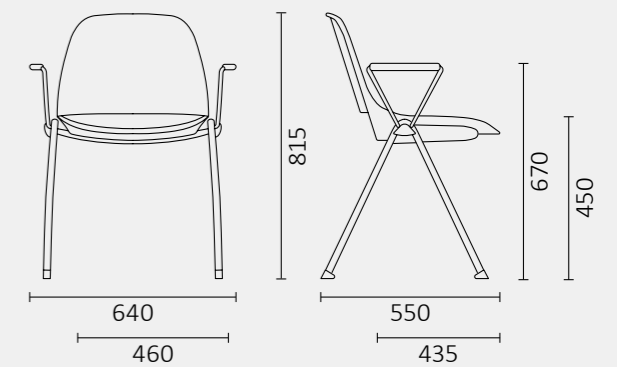
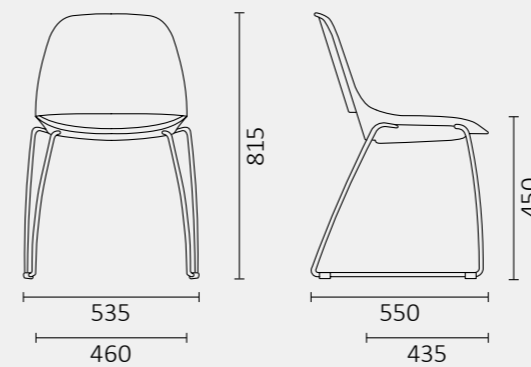

## ipa | R&d Leyform



Un design estremamente ricercato, una struttura robusta, e una facile configurazione di plastiche, basamenti e colori. Tutto questo è Ipa, un connubio tra eleganza e comfort che ti guida all'interno dell'area lavorativa e riesce, grazie alla sua praticità, ad elevare la tua esperienza ad uno step superiore. Inizia qui la naturale evoluzione del comfort.

A sophisticated design, a strong structure and many configuration of plastics and base colours. Ipa is all this, a combination of elegance and comfort that leads you throughout your workplace and thanks to its functionality will enhance your seating experience. The natural development of comfort starts from here.

Un design extrêmement soigné, une structure robuste, et une configuration fonctionnelle des plastiques piétements et couleurs. Tout cela est Ipa, un mariage de élégance et confort qui vous conduit à l'intérieur de l'espace de travail et arrive, grâce à sa praticité, à élever votre expérience à un niveau supérieur. D'Ici commence l'évolution naturelle du confort.

Ein extrem raffiniertes Design, eine robuste Struktur und eine einfache Konfiguration von Kunststoffen, Gestellen und Farben. All dies ist Ipa, eine Kombination aus Eleganz und Komfort, die Sie durch den Arbeitsbereich führt und dank seiner praktischen Anwendbarkeit Ihre Erfahrung auf ein höheres Niveau hebt. Hier beginnt die natürliche Entwicklung des Komforts.





**SCOCCA**  
shell / coque / Schale



**COLORI PLASTICHE**  
plastic colours / couleurs plastique / Kunststofffarben



**BASAMENTI**  
bases / piétements / Fussgestelle



**FINITURE**  
finishes / finitions / Gestellausführung



Monoscocca in polipropilene, base girevole in alluminio  
Polypropylene shell, swivel base in aluminium  
Monocoque en polypropylène, piétement en aluminium poli  
Formschalenstuhl aus Polypropylen,  
Fusskreuz aus Aluminium

252

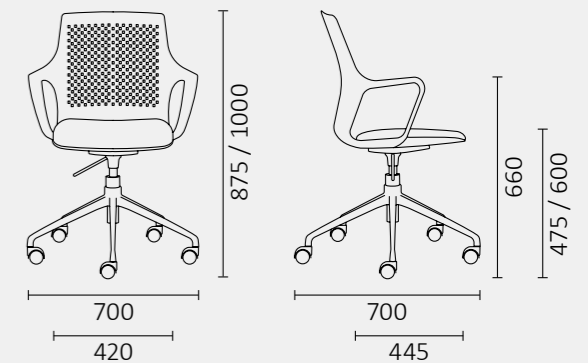
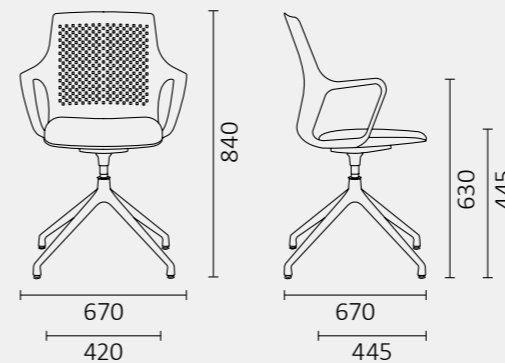

253



## zerosedici | *Simone Bolzan*



Zerosedici non è una sedia. È un'intera famiglia, che nasce per assecondare le esigenze della quotidianità. Configura la tua seduta scegliendo tra centinaia di varianti, e adattala al tuo stile di vita. Linee decise ma eleganti, semplicemente unica nel suo genere e facilmente adattabile al tuo ambiente.

Zerosedici is not simply a chair. It is a whole family, which has been created to meet daily needs. Construct your chair and adapt it to your lifestyle by choosing from hundreds of options. Clear-cut yet elegant lines, simply one of a kind and readily adaptable to your environment.

Zerosedici n'est pas une simple chaise. Elle représente toute une famille de produits conçue pour répondre aux besoins du quotidien. Définissez votre siège en le choisissant parmi une certaine de variantes adapté à votre style de vie. Se distinguant par ses lignes épurées mais élégantes, il est tout simplement unique dans son genre et aisément intégrable dans votre environnement.

Zerosedici ist kein Stuhl. Vielmehr handelt es sich um eine ganze Familie, die all den Erfordernissen gerecht wird, die das täglichen Leben mit sich bringt. Gestalten Sie Ihre Sitzgelegenheit, indem Sie unter hunderten von Varianten wählen, und passen Sie diese dabei Ihrem Lebensstil an. Entschlossene, aber elegante Linien, schlichtweg einzigartig in ihrer Art und leicht Ihrem Ambiente anpassbar.

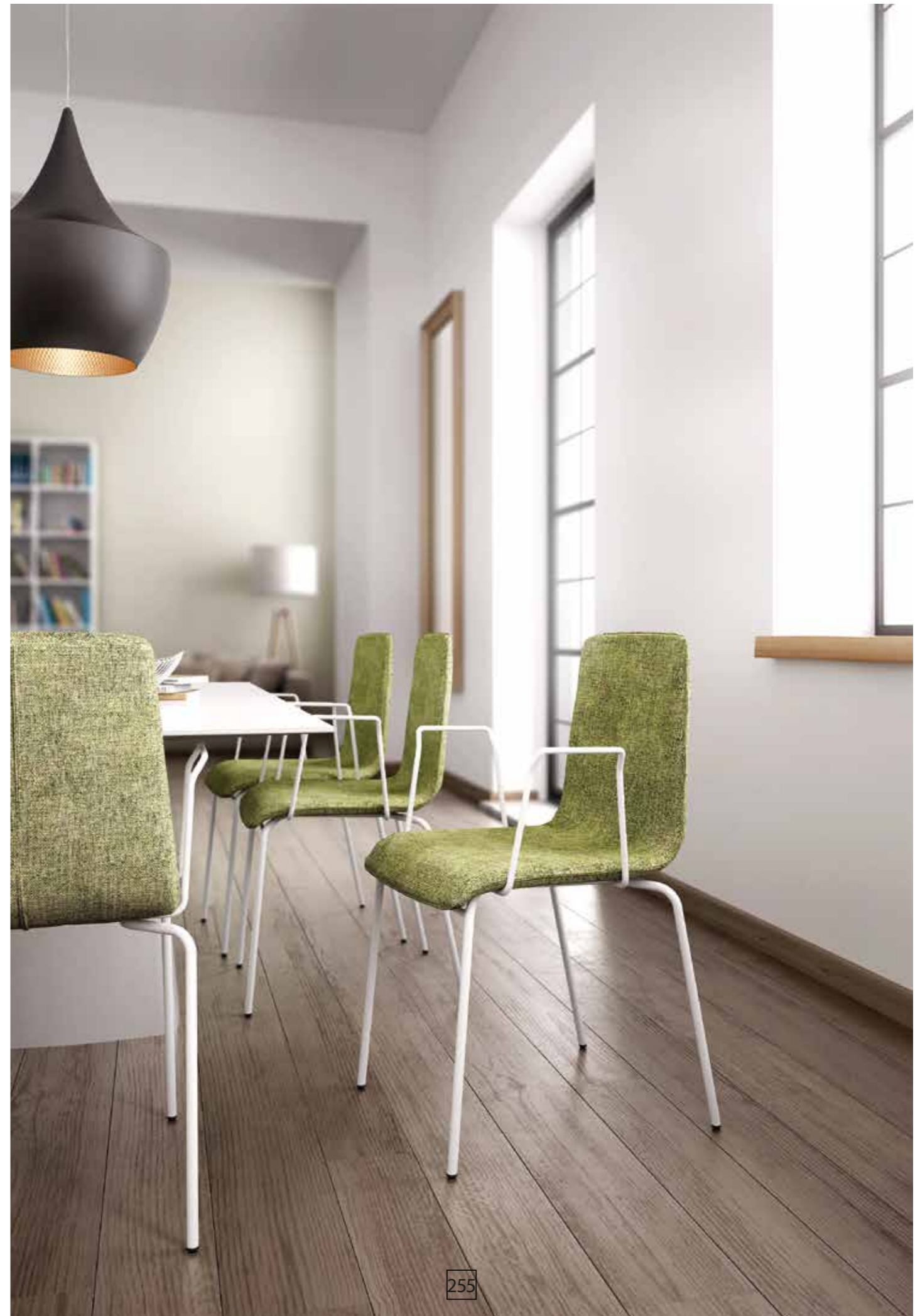

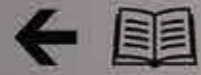



Monoscocca in legno curvato, braccioli fissi  
 Wood curved multilayer shell, fixed armrests  
 Contreplaqué moulé, accoudoirs fixes  
 Formschalenstuhl aus Buche, fixe Armlehnen

**SCOCCA**  
 shell / coque / Schale



**BRACCIOLI**  
 armrests / accoudoirs / Armlehnen



**BASAMENTI**  
 bases / piétements / Fussgestelle



**FINITURE**  
 finishes / finitions / Gestellausführung



**ACCESSORI**  
 accessories / accessoires / Zubehör

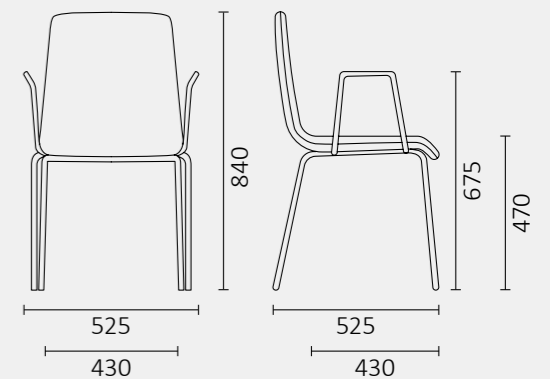
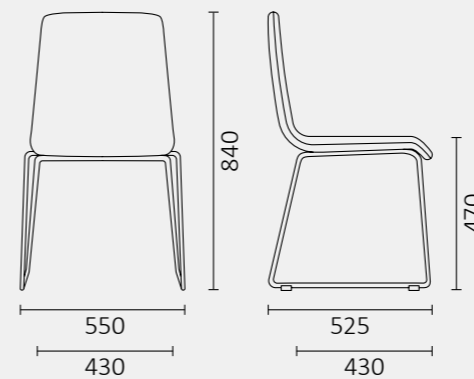

# claire | *Stefano Sandonà e Sabrina Bettini*



Grazie alle sue numerose sfaccettature Claire si propone come un vero passpartout: in grado di adattarsi ad ogni occasione. Che la tua stanza sia un ambiente casalingo, ricreativo, o magari lavorativo, Claire saprà adattarsi nel migliore dei modi, ma proponendo sempre un'estetica al passo con i tempi.

Thanks to its many faces, Claire proposes itself as a true passpartout able to adapt on every occasions. It doesn't matter if you are in a domestic or office environment, Claire will know how to make you comfortable, with its aesthetic in step with the times.

Grâce à ses multiples visages, Claire est un véritable passpartout: capable de s'adapter à toutes les occasions. Que votre pièce soit un environnement domestique, récréatif ou de travail, Claire saura s'adapter au mieux, mais en offrant toujours une esthétique dans l'air du temps.

Dank seiner vielen Vielfältigkeit, ist Claire ein echtes Passpartout: Sie kann sich jedem Anlass anpassen. Unabhängig davon, ob sich der Raum um ein Wohn-, Erholungsoder Arbeitsumfeld handelt, kann sich Claire bestmöglich anpassen, bietet jedoch stets eine zeitgemäße Ästhetik.

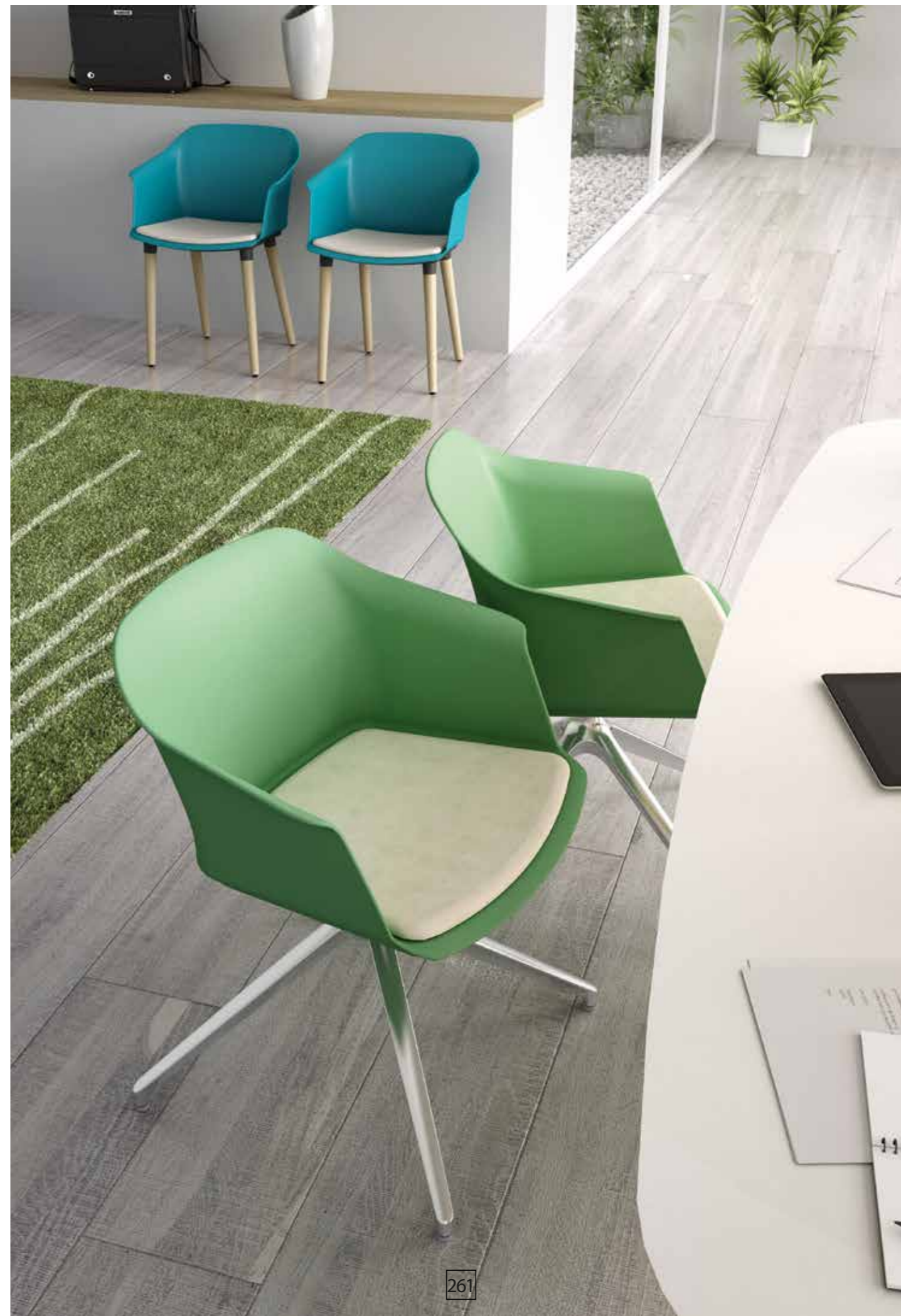





Dettaglio seduta, rivestimento in tessuto  
 Seat detail, fabric upholstery  
 Détail du assise, revêtement en tissu  
 Sesseldetail, Stoffbezug

264



**SCOCCA**  
 shell / coque / Schale

**COLORI PLASTICHE**  
 plastic colours / couleurs plastique / Kunststofffarben

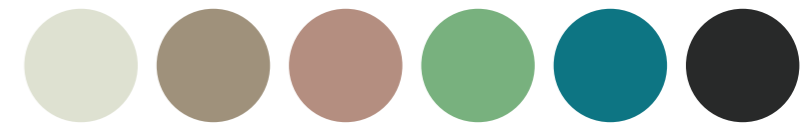

**BASAMENTI**  
 bases / piétements / Fussgestelle



**FINITURE**  
 finishes / finitions / Gestellausführung

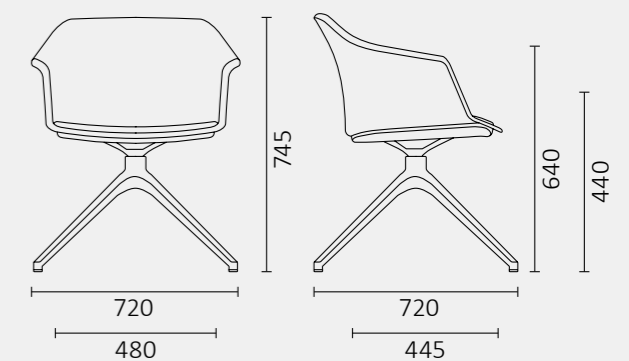
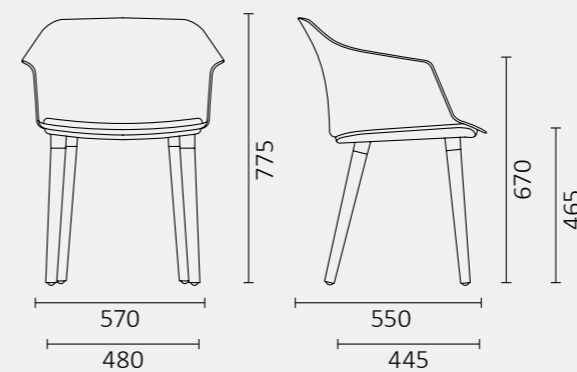

265

## greta | Act Design



Praticità e concretezza. Greta sorprende per il suo design essenziale e moderno. Semplice e dal sicuro impatto, strizza l'occhio all'ecosostenibilità, grazie alla variante con plastiche riciclate e riciclabili. Studiata per arricchire le tue giornate grazie alle sue linee leggere e confortevoli.

Functionality and concreteness. Greta surprises for its essential and modern design. Simple but with a clear visual impact, it also nods to eco-sustainability with its version in recycled and recyclable plastic. Designed to enrich your days thanks to its soft and comfortable lines.

Praticité et caractère concret. Greta surprend par son design essentiel et moderne. Simple et avec un impact certain, il fait un clin d'oeil à l'éco-durabilité, grâce à la variante avec des plastiques recyclés et recyclables. Conçu pour enrichir vos journées grâce à ses lignes légères et confortables.

Praktikabilität und Konkretheit. Greta überrascht mit seinem essentiellen und modernen Design. Einfach und mit sicherer Wirkung lässt es die ökologische Nachhaltigkeit dank der Variante mit recycelten und recycelbaren Kunststoffen hinter sich. Entwickelt, um Ihre Tage dank seiner leichten und bequemen Linien zu bereichern.





**SCOCCA**  
shell / coque / Schale



**ACCESSORI**  
accessories / accessoires / Zubehör



**IMPILABILITÀ**  
stackability / empilabilité / Stapelbarkeit



**COLORI PLASTICHE**  
plastic colours / couleurs plastique / Kunststofffarben



Monoscocca in polipropilene  
Polypropylene shell  
Monocoque en polypropylène  
Formschalenstuhl aus Polypropylen

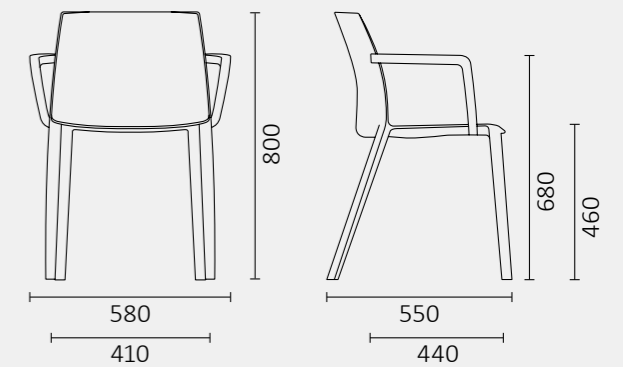
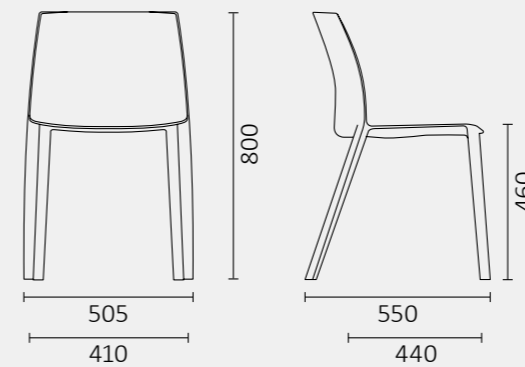



## laMia | R&d Leyform



La sedia. La più utilizzata, la più apprezzata, la più richiesta. Telaio robusto in acciaio con seduta e schienale imbottiti, in lamiera, polipropilene o legno. La struttura pulita ed essenziale permette una grande impilabilità in ogni tipo di ambiente. Adatta quando voglio una sola sedia: LaMia.

The chair. The icon. A sturdy frame chair, elegant and with an essential design. It offers a wide variety of colours and materials and it even stack up: it will save space too! I just want this chair. Mine: La Mia.

La chaise la plus aimée, la plus désirée, la seule que je veux, La Mia. Solide châssis en acier, dossier et assise rembourrés, en métal, polypropylène ou bois. Grâce à son design essentiel elle est empilable et vous donne la chance d'optimiser l'espace.

Der meistbenutzte, beliebteste und gefragteste Stuhl. Robuster Rahmen aus Stahl mit Sitz und Rückenlehne mit Polsterung, aus Blech, Polypropylen oder Holz. Die klare und schlichte Struktur sorgt für eine gute Stapelbarkeit in jeder Umgebung. Geeignet, wenn ich nur einen Stuhl will: 6940LAM LaMia.

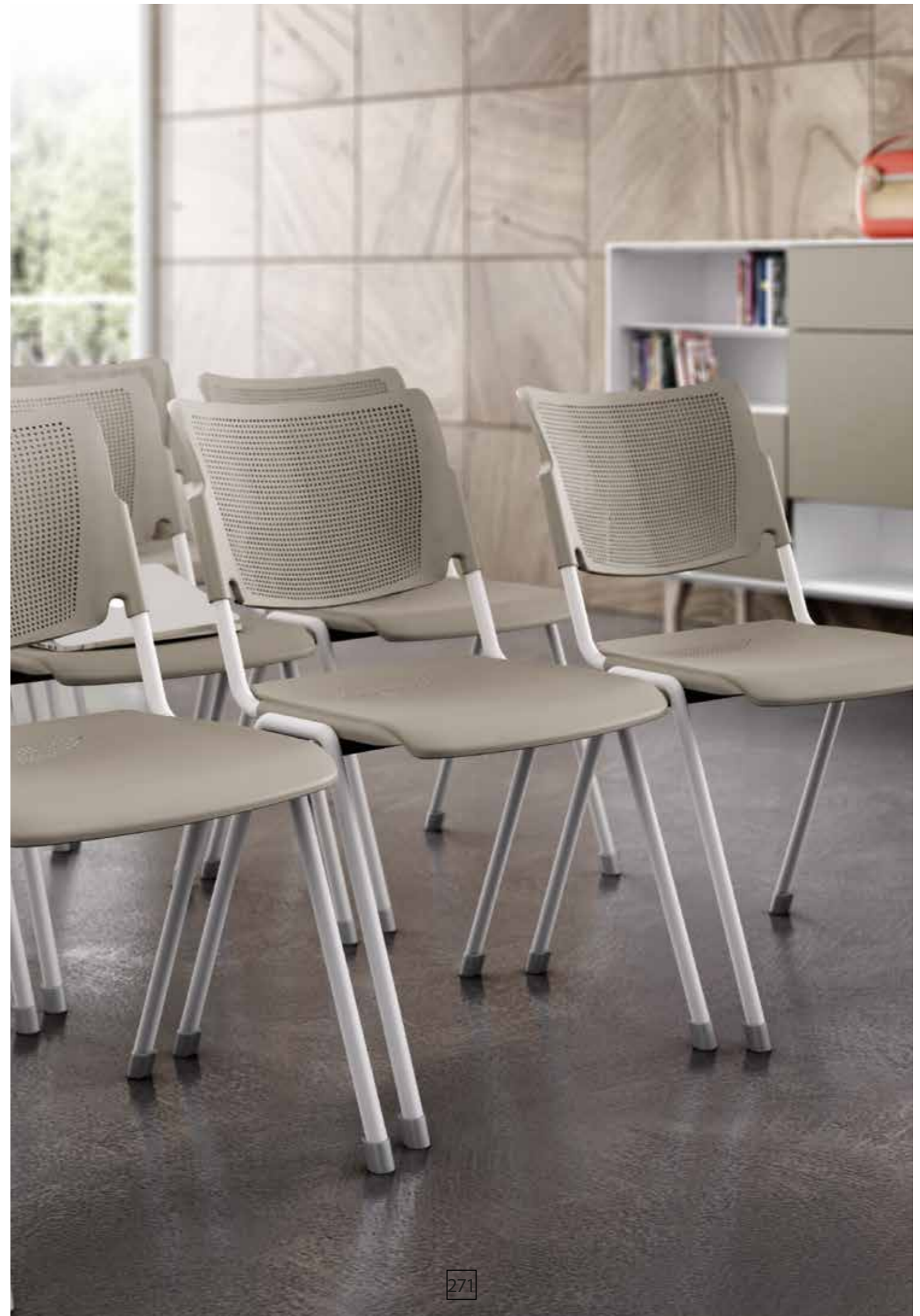



**SEDUTA**  
seat / assise / Sitz

**BRACCIOLI**  
armrests / accoudoirs / Armlehnen



**BASAMENTI**  
bases / piétements / Fussgestelle



**COLORI PLASTICHE**  
plastic colours / couleurs plastique / Kunststofffarben



**FINITURE TELAIO**  
frame finishes / finitions châssis / Gestellausführung



Sedile e schienale in polipropilene, telaio in acciaio verniciato grigio  
Polypropylene seat and backrest, gray painted steel frame  
Assise et dossier en polypropylène, Structure en acier peint gris  
Sitz und Rückenlehne aus Kunststoff, Gestell aus grau lackiertem Stahl

272

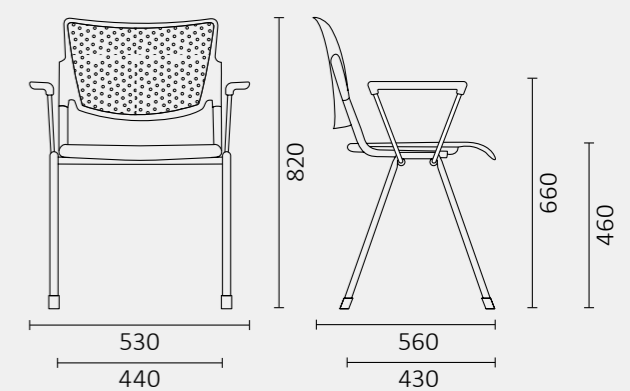
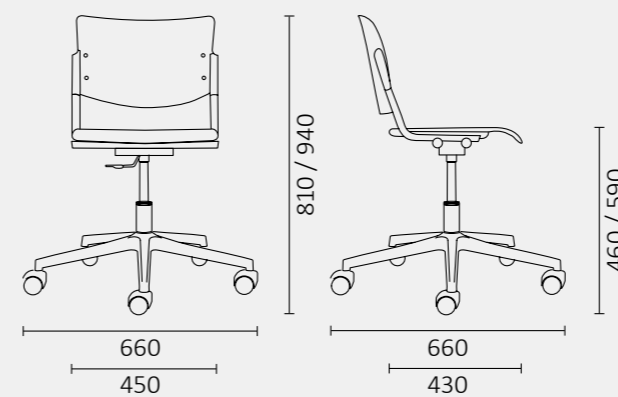

273

## cortina | *R&d Leyform*



Pensata come sedia per la collettività ma utile anche nel privato, Estremamente versatile e personalizzabile in pochi e semplici passi. Imbottita, in legno o polipropilene, con pratico cestello portacarte, bracciolo o tavoletta. Qualsiasi sia l'utilizzo, Cortina farà egregiamente il proprio lavoro.

Cortina, a versatile solution for public and private environments. The ideal solution for different working spaces, both private or public. Optional backrest, writing tablet and armchair, seat and back customizable... a perfect chair for different needs.

Siège collectif ou siège pour l'habitat? Mais pourquoi choisir ? Choisissez Cortina, le siège personnalisable: rembourré, en bois ou polypropylène, avec corbelle, accoudoir ou tablette écrite. Offrant aussi plusieurs configurations pour les différents emplois.

Gedacht als Stuhl für Gemeinschaftseinrichtungen, aber auch im Privatbereich nützlich, extrem vielseitig und in wenigen einfachen Schritten personalisierbar. Gepolstert, aus Holz oder Polypropylen, mit praktischem Ablagekorb, Armlehne oder Schreibplatte. Egal, wie er benutzt wird - Cortina leistet immer hervorragende Arbeit.



Dettaglio seduta, rivestimento in tessuto  
 Seat detail, fabric upholstery  
 Détail du assise, revêtement en tissu  
 Sesseldetail, Stoffbezug



276



**SEDUTA**  
 seat / assise / Sitz



**BRACCIOLI**  
 armrests / accoudoirs / Armlehnen



**FINITURE TELAIO**  
 frame finishes / finitions châssis / Gestellausführung

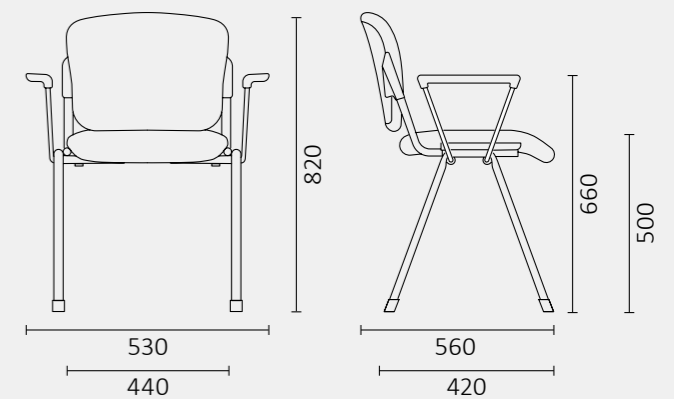

277

## valeria | *R&d Leyform*



Certificata per un utilizzo intenso e sottoposta ai più severi standard qualitativi. Troverai Valeria robusta e leggera al tempo stesso. Splendida in occasioni importanti, come meeting o sale conferenza dove l'impilabilità, unita alla disponibilità di tavoletta, braccioli e agganci laterali, fa la differenza.

Valeria combines lightweight and solid frame. Designed to adapt to different uses: meeting rooms, conference halls etc., this chair is also stackable and customizable by writing tablet, basket, linking device and armrest...choose the combination you prefer! A dynamic and practical solution recommended for the contract environment.

Valeria, le confort et la robustesse nécessaires à tous les usages. Des lignes sveltes caractérisent cette chaise capable de s'intégrer dans tout espace. Empilabilité, tablette écriteoire, accoudoir et pinces d'union: une solution dynamique et pratique pour le salles meeting ou congrès.

Der Stuhl ist zertifiziert für eine intensive Benutzung und hält die strengsten Qualitätsstandards ein. Valeria ist robust und gleichzeitig leicht. Hervorragend geeignet für wichtige Anlässe wie Meetings oder Konferenzräume, wo die Stapelbarkeit vereint mit der Verfügbarkeit von Schreibplatte, Armlehnen und Reihenverbindern den Unterschied machen.

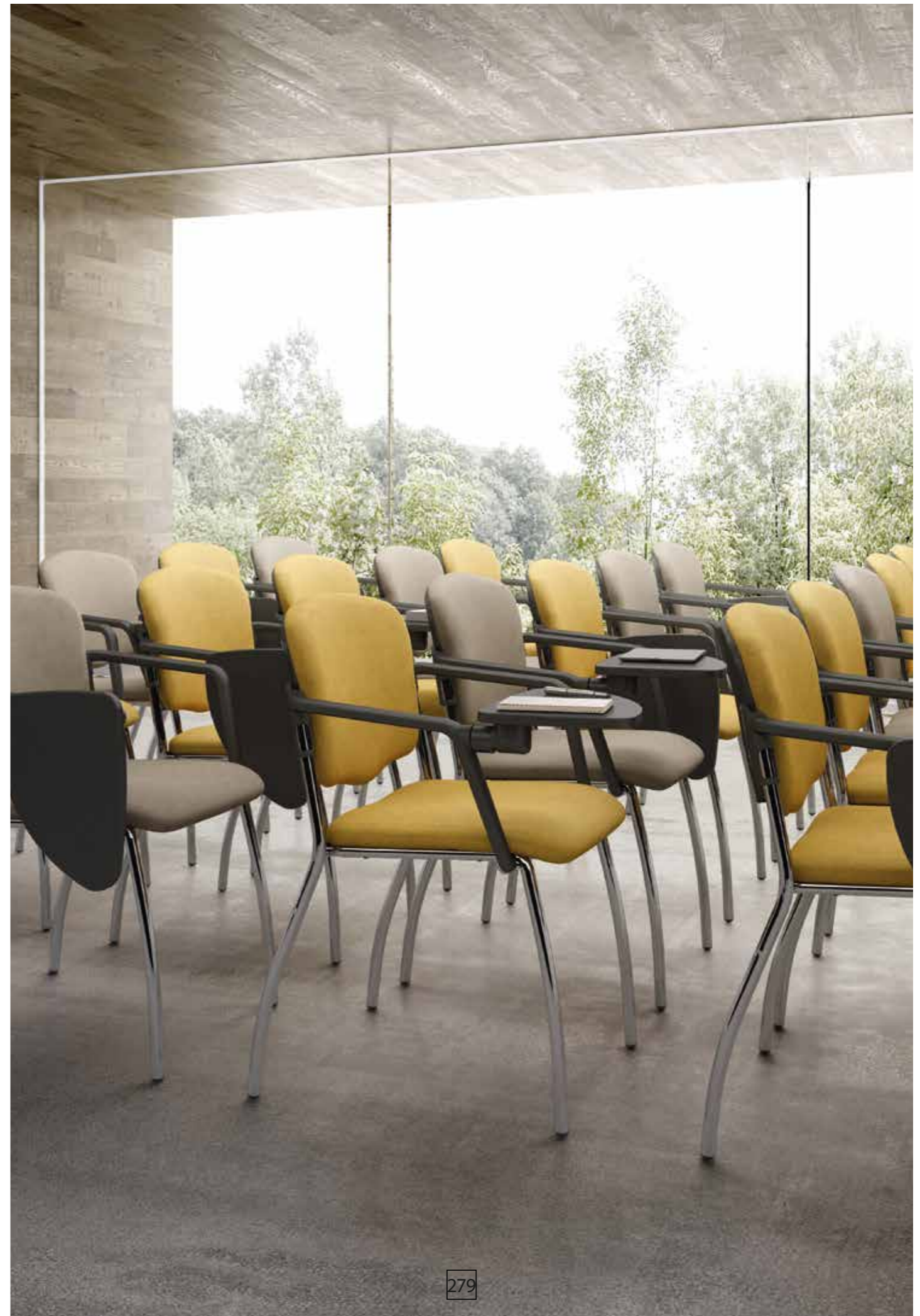



**BRACCIOLI**  
armrests / accoudoirs / Armlehnen

**FINITURE TELAIO**  
frame finishes / finitions châssis / Gestellausführung



**ACCESSORI**  
accessories / accessoires / Zubehör



Telaio in acciaio verniciato nero / grigio, tavoletta laterale opzionale  
Black / gray painted steel frame, optional side tablet  
Structure en acier peint noir / gris, tablette latérale en option  
Gestell aus schwarz / grau lackiertem Stahl,  
Optionales seitliches Tablar

280

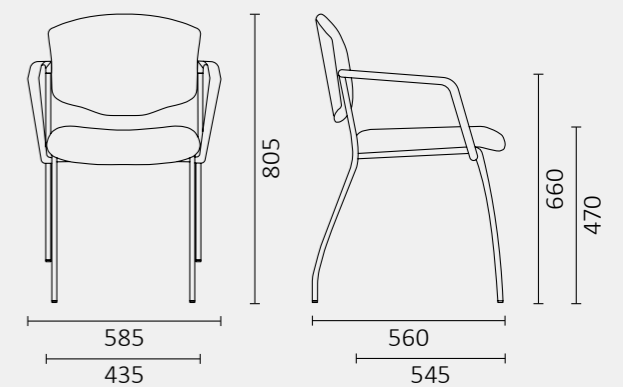

281

Telaio in acciaio verniciato nero / grigio,  
 rivestimento in tessuto  
 Black / gray painted steel frame,  
 fabric upholstery  
 Structure en acier peint noir / gris,  
 revêtement en tissu  
 Gestell aus schwarz / grau  
 lackiertem Stahl, Stoffbezug

## laila | R&d Leyform



Colorata, energica, bella, divertente. Aggettivi perfetti per descrivere la freschezza di Laila, una sedia adattabile ad ogni contesto, grazie anche allo schienale personalizzabile con colori e rivestimenti, che fanno risaltare il suo lato spiritoso e la sua indole estremamente giovanile e sbarazzina.

A colourful, dynamic, amazing, fresh and smart chair. Laila, a versatile chair for multiples sectors, a light and technological design for any space: its customizable back, by different colours and covers, underlines its smart dynamic design.

Couleur, énergie, beauté, divertissement. Le voilà Laila, un siège jeune, adaptable à quel que soit son environnement aussi grâce à son dossier personnalisable avec différents couleurs et revêtements.

Bunt, energisch, schön, fröhlich. Perfekte Adjektive, um die Frische von Laila zu beschreiben. Ein Stuhl der sich auch dank der Rückenlehne, die mit Farben und Bezügen personalisiert werden kann, die seine witzige Seite und sein extrem junges und unkompliziertes Wesen hervorheben, perfekt a 0580 n jede Umgebung anpasst.

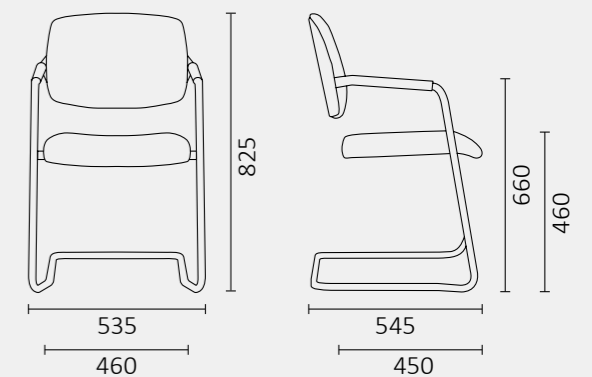
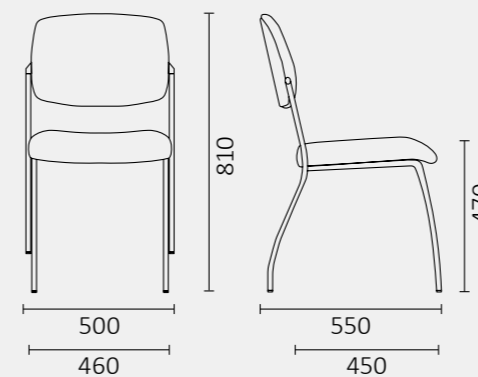

Rivestimento in tessuto, base a slitta  
 Fabric upholstery, sled base  
 Revêtement en tissu, piètement luge  
 Stoffbezug, Freischwingergestell

# spot | *Stefano Sandonà e Sabrina Bettini*



Il telaio in acciaio indeformabile unisce basamento e braccioli in un'unica linea. Con lo schienale in quattro colorazioni e la seduta personalizzabile in differenti categorie, Spot si adatta perfettamente ad ogni contesto, strizzando l'occhio anche all'ambiente casa.

Spot, a monoblock chair with a sturdy steel frame, backrest available in 4 colours and seat customizable. This chair is perfect for any workplace and it's also a suitable homechair... Why not?

Une seule structure en acier indéformable pour piètement et accoudoirs. Assise et dossier personnalisables dans plusieurs couleurs et revêtements. Spot, le siège parfait pour les espaces bureaux et pour ceux privés aussi... pourquoi pas?

Eine durchgehende Schale aus unverformbarem Stahl vereint Fußgestell und Armlehnen in einer einzigen Linie. Mit der Rückenlehne in vier Farben und dem in unterschiedlichen Kategorien personalisierbaren Sitz passt sich Spot perfekt in jedes Ambiente ein und macht auch in der häuslichen Umgebung eine gute Figur.

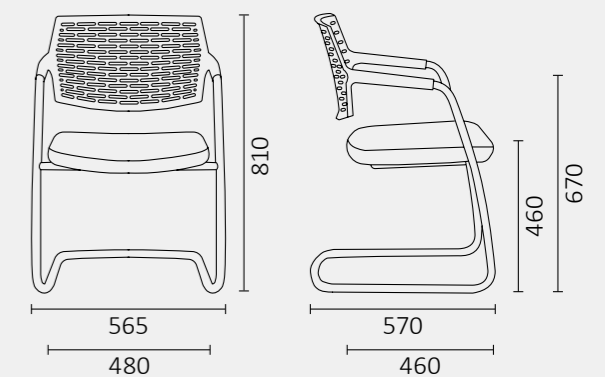



# gardena | *R&d Leyform*



Grazie alla struttura in acciaio e alle moltissime colorazioni presenti Gardena si fa notare come sedia più divertente e spiritosa. Una scocca in multistrato sagomato per riprendere le linee del corpo, leggera e robusta al tempo stesso. Il pratico carrello infine è utile per trasportarla in grandi quantità.

Gardena, the amazing and dynamic stackable chair, with metal frame and ergonomic seat, available in various optional colours. Thanks to its particular design, it is a smart and decorative chair. Metal frame and beechwood shell. Available trolley to store and transport it easily.

Gardena: grâce à sa structure en acier et aux plusieurs couleurs optionnelles elle vous montre son côté désinvolte et très personnel. Son design particulier suit les lignes du corps en donnant à cette chaise une silhouette exceptionnelle aux traits sveltes. Son style dynamique se complète avec un chariot pour le rangement et le transport.

Dank des Gestells aus Stahl und vielen Farben präsentiert sich Gardena als fröhlicher und witziger Stuhl. Eine leichte und gleichzeitig robuste Schale aus geformtem Schichtholz nimmt die Linien des Körpers auf. Der praktische Transportwagen ist nützlich, um ihn in großer Zahl zu transportieren.

Monoscocca in legno curvato, telaio in acciaio cromato  
Wood curved multilayer shell, chromed steel frame  
Contreplaqué moulé, structure en acier chromé  
Formschalenstuhl aus Buche, Gestell aus verchromtem Stahl

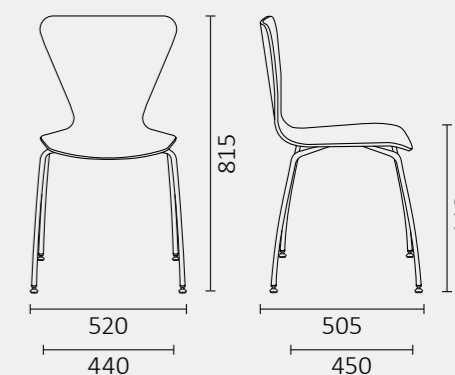

# cristallo | *R&d Leyform*



Seduta e schienale in faggio verniciato naturale e base cromata. Cristallo propone una seduta lineare ed essenziale, facilmente impilabile e trasportabile grazie all'apposita maniglia. Semplice da usare e ideale in molteplici utilizzi. Può essere anche corredata da un pratico cuscino in tessuto, e con utili agganci laterali.

Metal frame, natural beechwood back and seat, slender and simple lines easily to store and transport thanks to its handle. This chair is a practical solution for all situations. Available with linking device and an optional comfortable fabric seat pad.

Cristallo: la chaise qui s'adapte à tout. Avec ses lignes fluides et essentielles elle est légère et facile à stocker grâce à la poignée du dossier. Assise et dossier en bois d'hêtre et structure chromée, avec système d'accrochage intégré et coussin tissu optionnel. Une solution pratique pour les différents usages.

Sitz und Rückenlehne aus Buchenholz mit Natur-Lackierung und verchromtem Fußgestell. Cristallo präsentiert einen linearen und schlichten Sitz und ist dank des Griffs einfach stapel- und transportierbar. Benutzungsfreundlich und ideal für zahlreiche Verwendungen. Standardmässig mit Reihenverbindern und optionell mit Sitzpolsterauflage aus Stoff ausgestattet.



Monoscocca in legno curvato, telaio in acciaio cromato  
Wood curved multilayer shell, chromed steel frame  
Contreplaqué moulé, structure en acier chromé  
Formschalenstuhl aus Buche, Gestell aus verchromtem Stahl

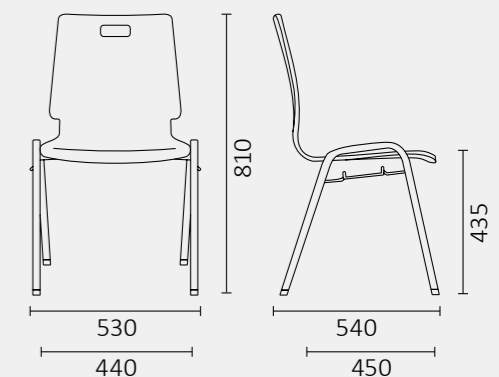

## arcade | R&d Leyform



Dalle poche pretese, dai molti vantaggi. Una vera fuoriclasse degli spazi ristretti o quando improvvisamente aumenta il numero di persone. Arcade, con la sua semplicità e leggerezza moltiplica lo spazio in pochi gesti ed è facilmente riponibile e trasportabile anche grazie al pratico carrello portasedie.

Arcade, a dynamic and practical solution to quickly seat your guests or for small spaces, with a slim and light design. The available trolley to store and transports the chairs completes its dynamic style.

Une solution pratique et dynamique pour les espaces exigus ou s'il vous faut des sièges supplémentaires: Arcade, ligne simple, légère et dynamique, son style pratique se complète avec un chariot pour le rangement et le transport.

Wenige Ansprüche, viele Vorteile. Der Hit für wenig Platz oder wenn die Personenzahl plötzlich steigt. Arcade vergrößert den Platz mit seiner Einfachheit und Leichtigkeit mit wenigen Handgriffen und kann dank des praktischen Transportwagens leicht weggeräumt und transportiert werden.



Sedia pieghevole, Gambe acciaio cromato  
Folding chair, chromed steel legs  
Chaise pliante, pieds en acier chromé  
Klappstuhl, Füße aus verchromtem Stahl

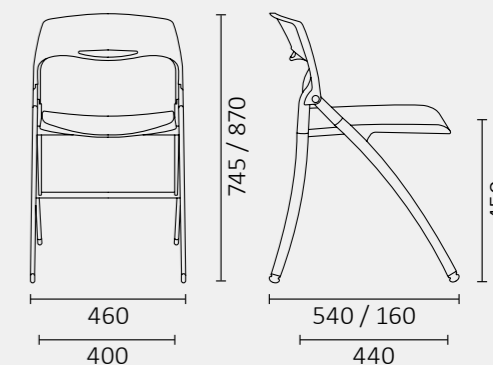

## panche | *R&d Leyform*



Imbottite, in legno, polipropilene o in lamiera. Pensate apposta per la collettività e gli spazi pubblici, le panche Leyform permettono una facile configurazione, presentando sempre la tipologia più adatta alle necessità di ogni spazio, con la stessa comodità che da sempre distingue tutta la nostra produzione.

Padded, in wood, polypropylene or metal plate. Designed for collectivities and public spaces, Leyform benches are conceived to provide a functional configuration, always supplying the best solution for different locations and needs. No matter in which solution, they will always keep the feeling of comfort that distinguishes all our collections.

Tapissées, en bois, en Polypro ou en tôle d'acier. Conçues exprès pour la collectivité et les aires publiques, les banquettes Leyform permettent une configuration fonctionnelle, présentant toujours la solution la plus indiquée aux nécessités de chaque espace, toujours en garantissant le même confort qui caractérise toutes nos collections.

Gepolstert, Holz- Polypropylen- oder Lochblechsausführung. Leyform Traversenbänke wurden speziell für die Kollektivität und öffentliche Räume gedacht. Sie ermöglichen eine einfache Konfiguration und passen sich allen Bedürfnissen an, mit dem gleichen Komfort und schon immer unsere Produktion auszeichnet.



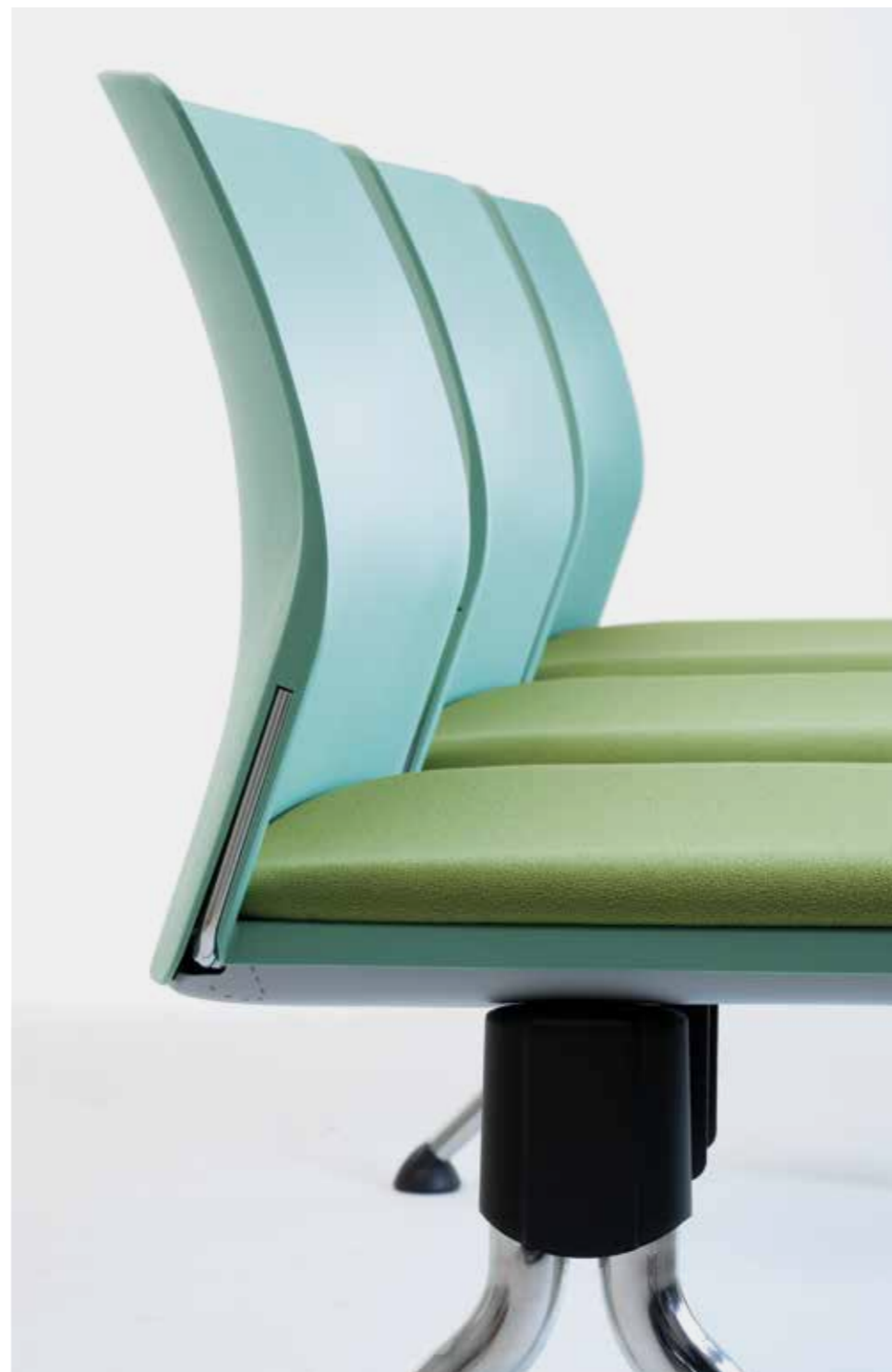

Sedile e schienale in polipropilene,  
gambe in acciaio cromato  
Polypropylene seat and backrest,  
chromed steel legs  
Assise et dossier en polypropylène,  
pieds en acier chromé  
Sitz und Rückenlehne aus Kunststoff,  
Füsse aus verchromtem Stahl



Rivestimento in tessuto, gambe in acciaio cromato  
Fabric upholstery, chromed steel legs  
Revêtement en tissu, pieds en acier chromé  
Stoffbezug, Füsse aus verchromtem Stahl

294

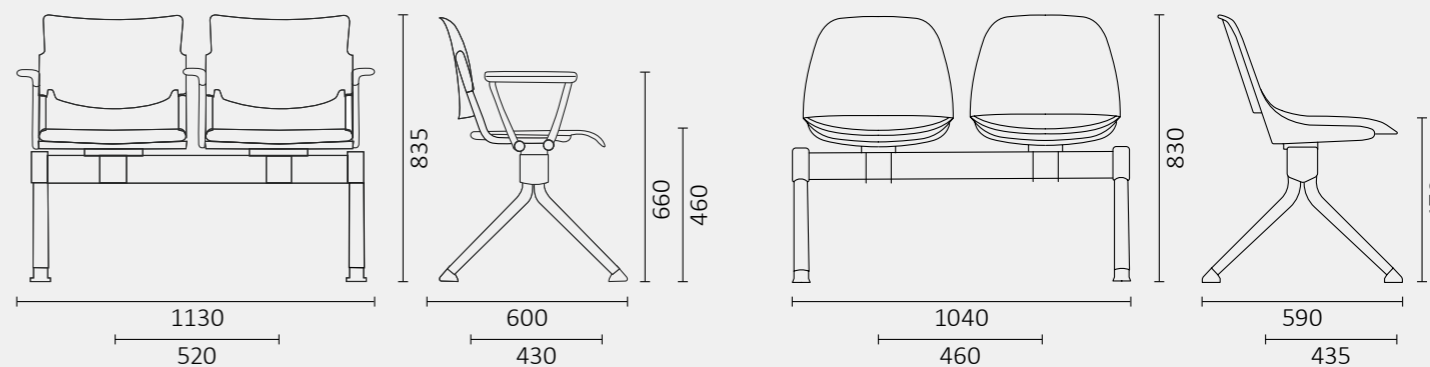

295

## tavoli | *Leyform*



snap | 298



artika | 302



eos | 306



arno | 310



uni | 314

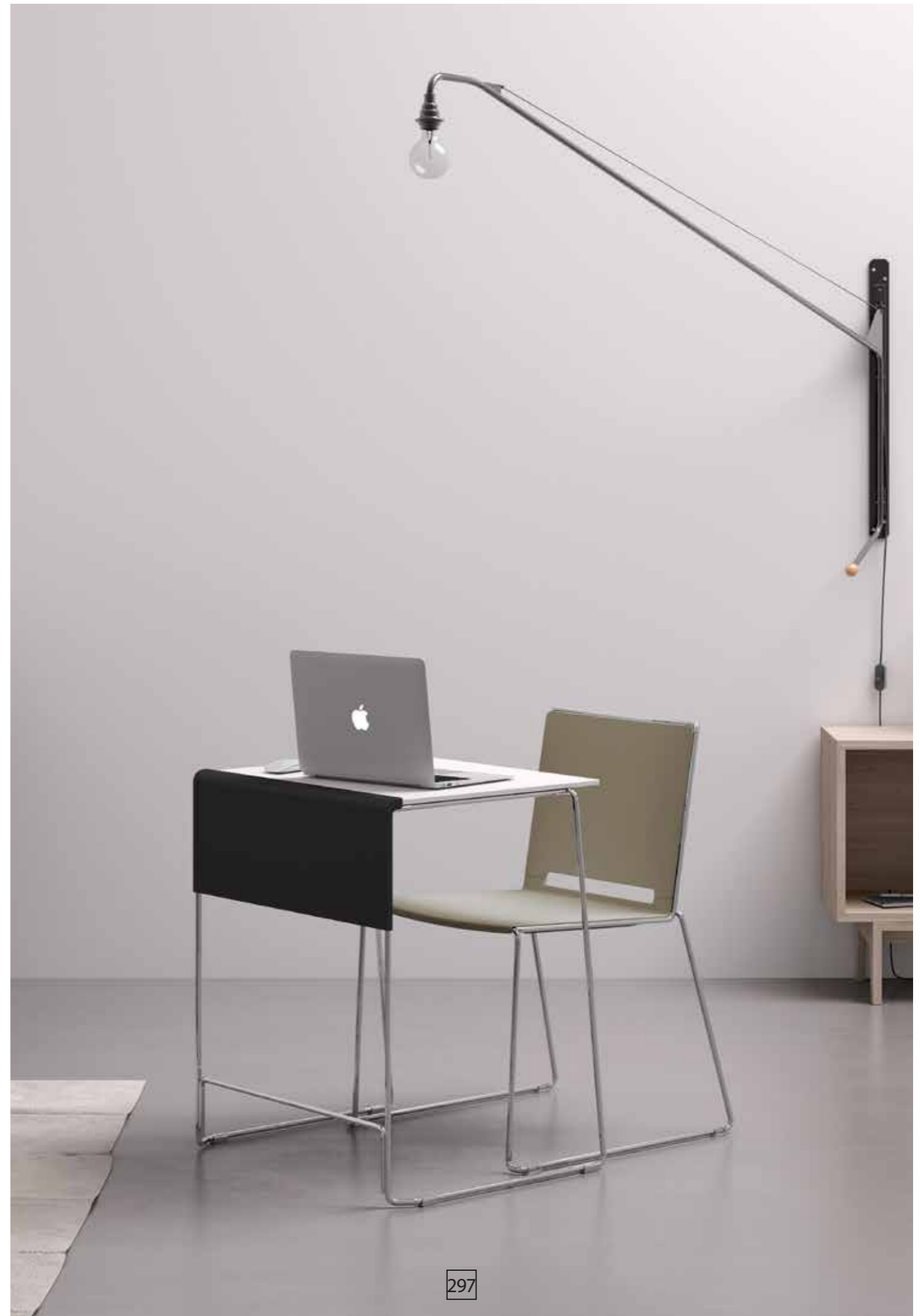

## snap | R&d Leyform



Una struttura esile ma allo stesso tempo solidissima. Snap sorprende per la sua robustezza, e per la sua grande versatilità. E' piccolo ma comodo, e può essere impilato fino a 10 pezzi e riposto con grande facilità. Con i pratici agganci sottostanti infine può essere facilmente collegato lateralmente per una maggiore stabilità.

A slim yet solid structure. Snap surprises with its robustness and great versatility. It is small but comfortable and can be stacked up to 10 pieces for easy storage. With the practical linking devices underneath, it can be easily linked at the sides for greater stability.

Une structure mince mais très solide. Snap surprend par sa robustesse et sa grande polyvalence. Il est petit mais confortable, et peut être empilé jusqu'à 10 pièces pour un rangement facile. Avec le système d'accrochage pratiques situés en dessous, il peut être facilement fixé sur les côtés pour être plus stable.

Eine schlanke und doch solide Struktur. Snap überrascht durch seine Robustheit und große Vielseitigkeit. Er ist klein, aber praktisch und kann zur einfachen Aufbewahrung bis zu 10-fach gestapelt werden. Mit den praktischen Haken an der Unterseite lässt er sich für mehr Stabilität leicht an den Seiten befestigen.





300

Piano tavolo in HPL bianco, telaio in acciaio cromato  
 Table top in white HPL, chromed steel frame  
 Plateau de table en HPL blanc, structure en acier chromé  
 Tischplatte aus weissem HPL, Gestell aus verchromtem Stahl

**VARIANTI**

versions / variantes / Varianten



**FINITURE**

finishes / finitions / Gestellausführung



**ACCESSORI**

accessories / accessoires / Zubehör

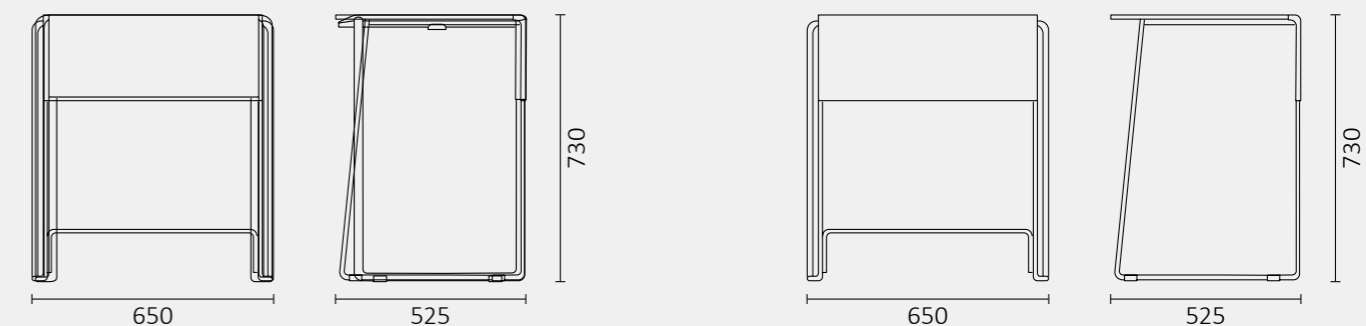

301



## artika | R&d Leyform



Introducendo Artika, il tavolo che custodisce un segreto funzionale. Grazie al suo ingegnoso meccanismo, si rivela indispensabile quando la gestione ottimizzata dello spazio è essenziale. Con una vasta gamma di colori, altezze, finiture e dimensioni, si trasforma nell'alleato ideale per arredare gli ambienti con facilità, apportando contemporaneamente un tocco distintivo di design.

Introducing Artika, the table that holds a practical secret. Thanks to its ingenious mechanism, it is essential when optimised space management is required. With a wide range of colours, heights, finishes and sizes, it becomes the ideal partner for furnishing spaces with ease while bringing a distinctive touch of design.

Voici Artika, la table qui recèle un secret fonctionnel. Grâce à son mécanisme ingénieux, elle se révèle indispensable lorsqu'il s'agit d'optimiser la gestion de l'espace. Avec une large gamme de couleurs, hauteurs, finitions et dimensions, elle devient l'alliée idéale pour meubler les espaces avec facilité tout en apportant une touche de design distinctive.

Wir stellen Artika vor, den funktionellen Tisch. Dank seines Mechanismus ist er essentiell, wenn es darum geht, den Raum optimal zu nutzen. Mit einer großen Farb-, Höhen- und Größenauswahl ist er ideal, um Räume leicht einzurichten und gleichzeitig einen besonderen Stil zu schaffen.





**PIANO TAVOLO**  
table top / plateau table / Tischplatte



**FINITURE**  
finishes / finitions / Gestellausführung



**TELAIO**  
bases / châssis / Gestell



Piano tavolo in HPL, telaio verniciato in tinta  
Table top in HPL, frame painted in the same color  
Plateau de table en HPL, châssis peint dans le même coloris  
Tischplatte aus HPL, Gestell in der gleichen Farbe lackiert

304

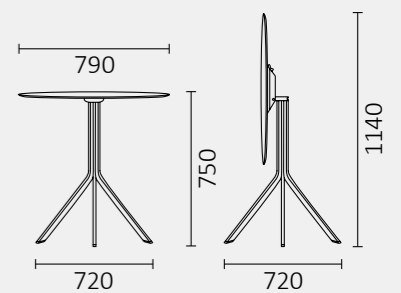
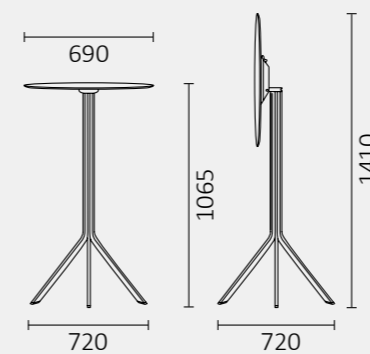

305

**eos** | *R&d Leyform*



Minimalismo spinto e un design attuale per dei tavoli che portano una ventata di novità in ogni ambiente. Basso e largo oppure alto e stretto, scegli la configurazione che più ti piace e gioca con i colori a tua disposizione. Eos lascia finalmente libera la tua voglia di arredare lo spazio.

Minimalism and modern design for this table, Eos is the perfect solution for any space. Available with different widths and heights, choose the model and play with the colors at your disposal to furnish your space as you want. Eos, feel free to decorate your own room as you see fit.

Design minimal et contemporain pour Eos, la table capable de meubler n'importe quel espace. Disponible en plusieurs largeurs et hauteurs, choisissez la forme que vous préférez et jouez avec les couleurs à votre disposition. Eos laisse libre votre envie de meubler votre place selon votre goût.

Minimalismus, Geist und ein aktuelles Design für die Tische, die frischen Wind in jeden Raum bringen. Niedrig und breit oder hoch und schmal, wählen Sie ihren Favoriten aus und spielen Sie mit den verfügbaren Farben. Eos lässt Ihrem Spaß am Einrichten freie Hand.





Piano tavolo in MDF verniciato, telaio in acciaio verniciato nero  
 Painted MDF table top, black painted steel frame  
 Plateau de table en MDF verni, structure en acier peint noir  
 Lackierte MDF-Tischplatte,  
 Gestell aus schwarz lackiertem Stahl

308

**PIANO TAVOLO**  
 table top / plateau table / Tischplatte



**TELAIO**  
 bases / châssis / Gestell



**FINITURE PIANO DEL TAVOLO**  
 finishes / finitions / Gestellausführung

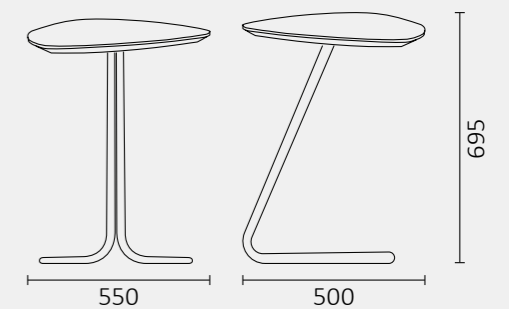
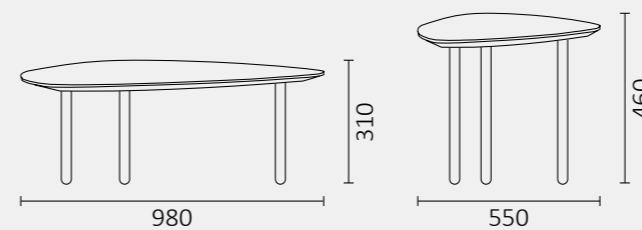
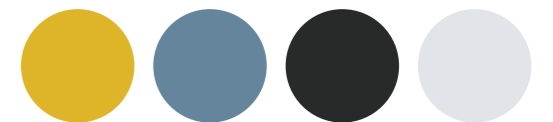

309

## arno | R&d Leyform



La famiglia di tavoli multifunzione Arno comprende tre modelli unici: Arno 3, disponibile in 6 dimensioni, robusto e versatile. Arno 4, snello e con gambe pieghevoli, è ideale per l'home office, ottimizzando lo spazio. Arno 5, dotato di ruote e freno, con il suo piano pieghevole in verticale, è facile da impilare e offre una grande flessibilità in termini di spazio.

The multifunctional table family Arno includes three unique models: Arno 3, which is available in 6 sizes, is robust and versatile. Arno 4, slim and with folding legs, is ideal for the home office, optimising space. Arno 5, equipped with castors and lock, with its vertically folding top, is easy to stack and offers great flexibility in terms of space.

La famille de tables polyvalentes Arno comprend trois modèles uniques : Arno 3, disponible en 6 dimensions, se caractérise par sa robustesse et sa versatilité. Arno 4, fine et avec des pieds pliables, est idéale pour le bureau à la maison, en optimisant l'espace. Arno 5, équipé de roulettes et d'un frein, avec son plateau rabattable verticalement, est facile à empiler et offre une grande flexibilité dans l'espace.

Die Arno-Tischfamilie hat drei besondere Modelle: Arno 3 ist robust und in 6 Größen erhältlich. Arno 4 ist schlank mit klappbaren Füßen, perfekt für das Homeoffice und optimiert den Platz. Arno 5, mit Rollen und Arretierung, ist mit seiner senkrecht klappbaren Tischplatte, dass das Stapeln erleichtert und viel Flexibilität bietet.

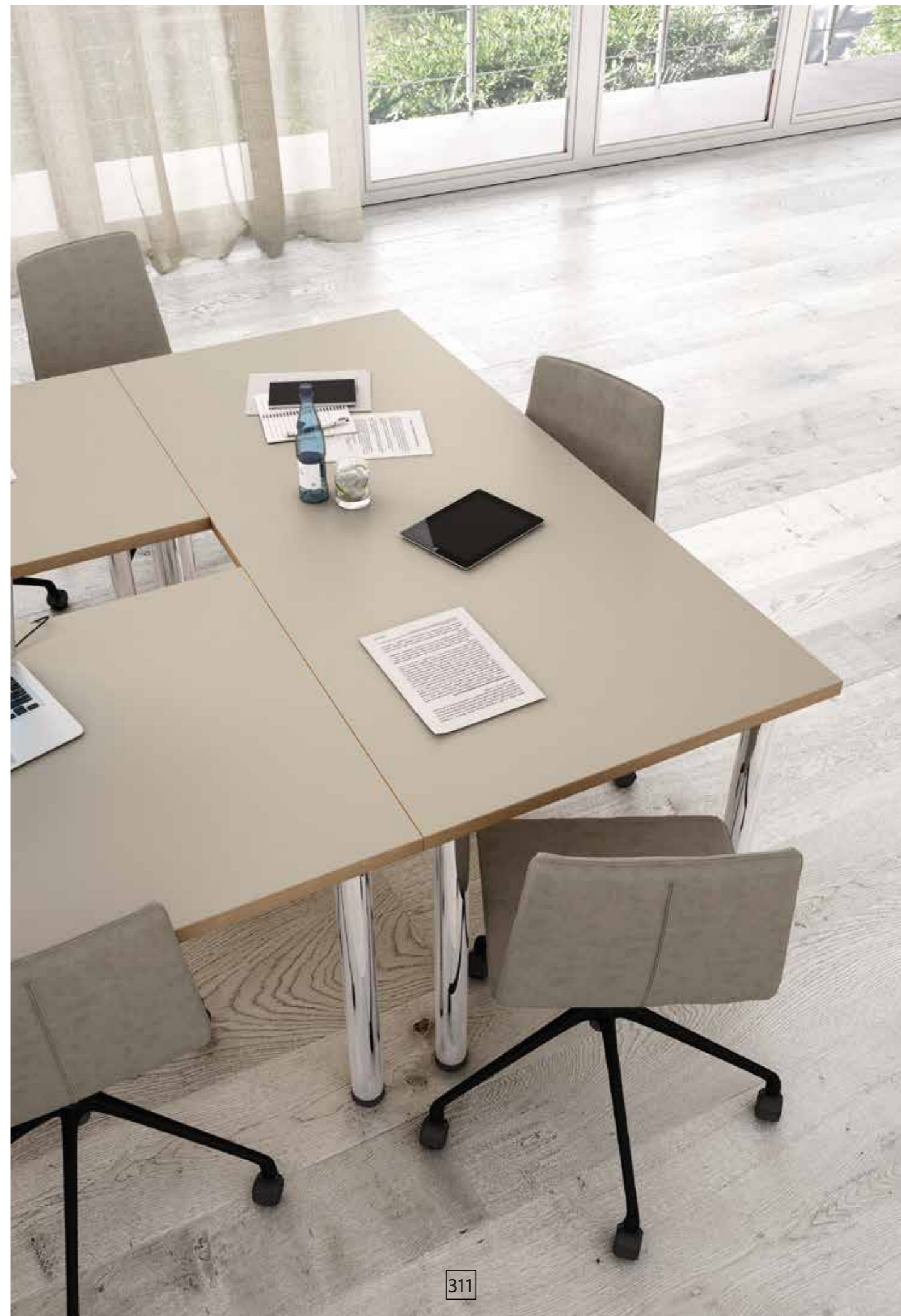



312

Piano tavolo in bilaminato color sabbia  
 Table top in sand-coloured bilaminate  
 Plateau de table en bilaminé couleur sable  
 Kunststoffbeschichtete Tischplatte sandfarbig



**TELAIO**  
 bases / châssis / Gestell

**FINITURA TELAIO**  
 finishes / finitions / Gestellausführung



**FINITURA PIANO TAVOLO**  
 finishes / finitions / Gestellausführung

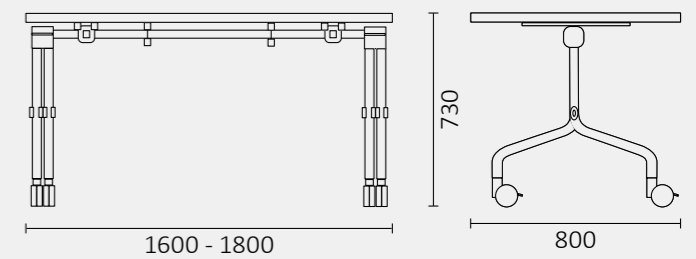
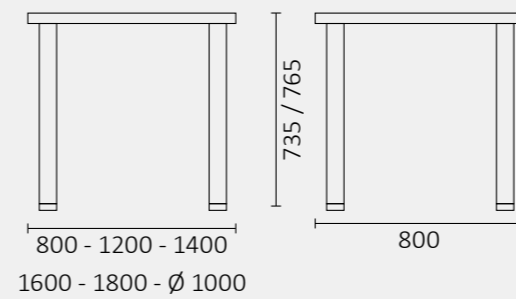

313

## uni | R&d Leyform



Attraverso un sistema sicuro e collaudato nel tempo i nostri tavoli da università Uni sono ideati per grandi aule e ambienti accademici. Configurabili in lunghezza da due a cinque posti, garantiscono una facile esperienza d'uso, trovando collocazione nella didattica e nella formazione accademica.

A robust and practical university desk with a simple line. Uni is a simple but functional table available between two to five seats and it is the great furnishing solution for university rooms or conference halls.

Formes simples, résistance et flexibilité sont quelques caractéristiques qui définissent nos tables Uni modulables de deux à cinq places, conçues pour les universités et les salles de cours. Simplicité et fonctionnalité pour les postes de formation et d'étude.

Über ein sicheres und durch die Zeit bewährtes System wurden unsere Universitätstische Uni für große Hörsäle und Seminarräume geschaffen. Zusammenstellbar in Längen mit zwei bis fünf Sitzplätzen garantieren sie Benutzungsfreundlichkeit und finden ihren Platz in der Didaktik und akademischen Ausbildung.

Piano tavolo con lunghezza da 2 a 5 posti  
Modesty panel in acciaio verniciato nero,  
Table top with length from 2 to 5 seats,  
Modesty panel in black painted steel  
Longueur du plateau de 2 à 5 places,  
Panneau frontal en acier peint en noir  
Tischplattenlänge von 2 bis 5 Sitzplätzen,  
Metallabdeckblende aus schwarz  
lackiertem Stahl

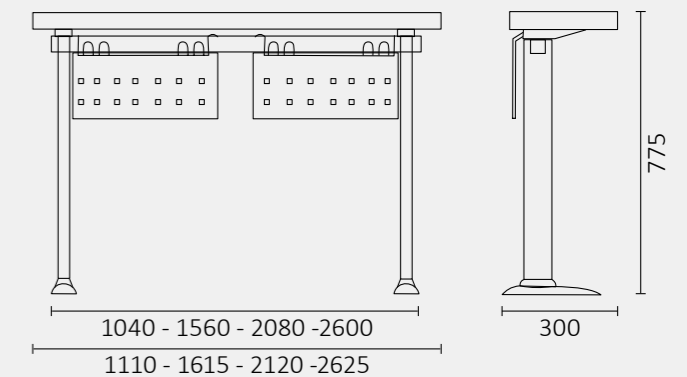
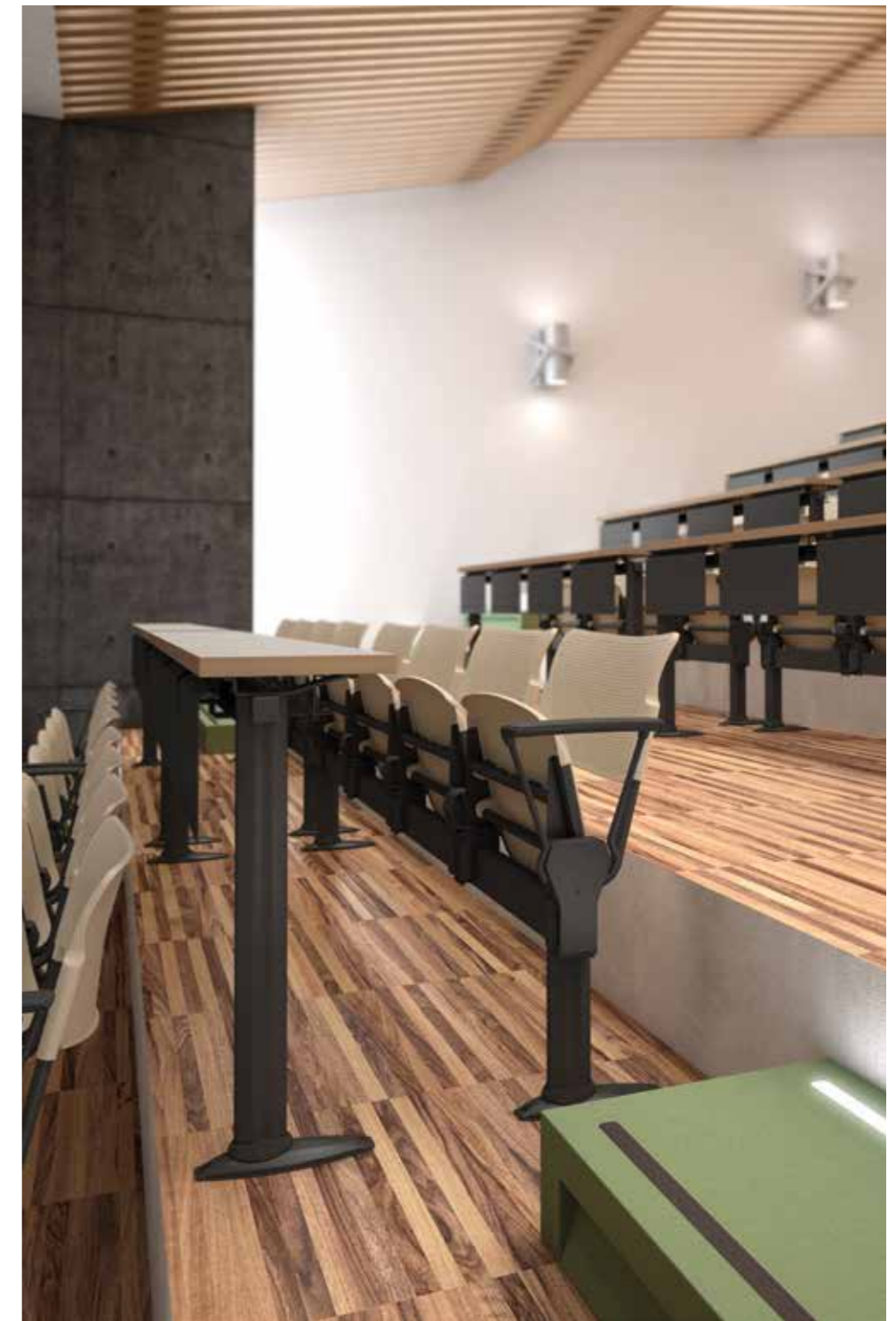

# rivestimenti | *Leyform*

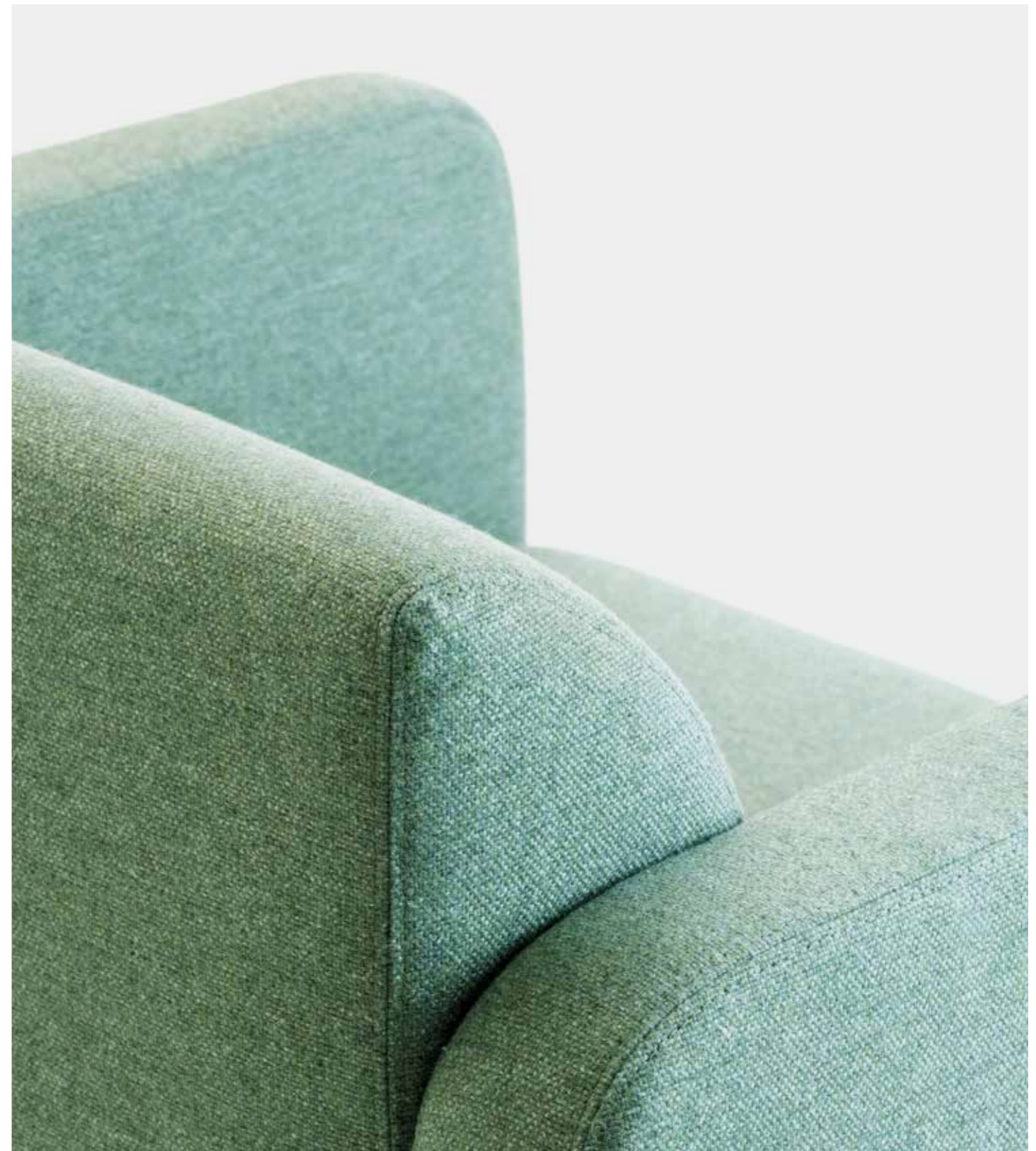

Le scansioni fotografiche dei tessuti/plastiche possono differire dai colori reali. Verificare i colori con quelli delle cartelle fisiche.

Photographic scans of fabrics/plastics may differ from the real ones. Check the colours with the physical charts.

Les images des tissus/plastiques peuvent différer de la réalité. Vérifiez les couleurs par rapport aux dossiers physiques.

Fotographische Abbildungen der Bezüge und Kunststofffarben sind annähernd. Bitte prüfen Sie mit den echten Farbmusterkarten



# serie 200 | categoria B

300 ± 5% g/m<sup>2</sup> / Martindale: 100.000 / Pilling: 5 / Xenotest: 6 / Flammability: ~~X~~  
100% Polyester Trevira CS



# time | categoria B

350 ± 5% g/m<sup>2</sup> / Martindale: 100.000 / Pilling: 5 / Xenotest: 6 / Flammability: ~~X~~  
50% Recycled polyester, 50% Polyester Trevira CS

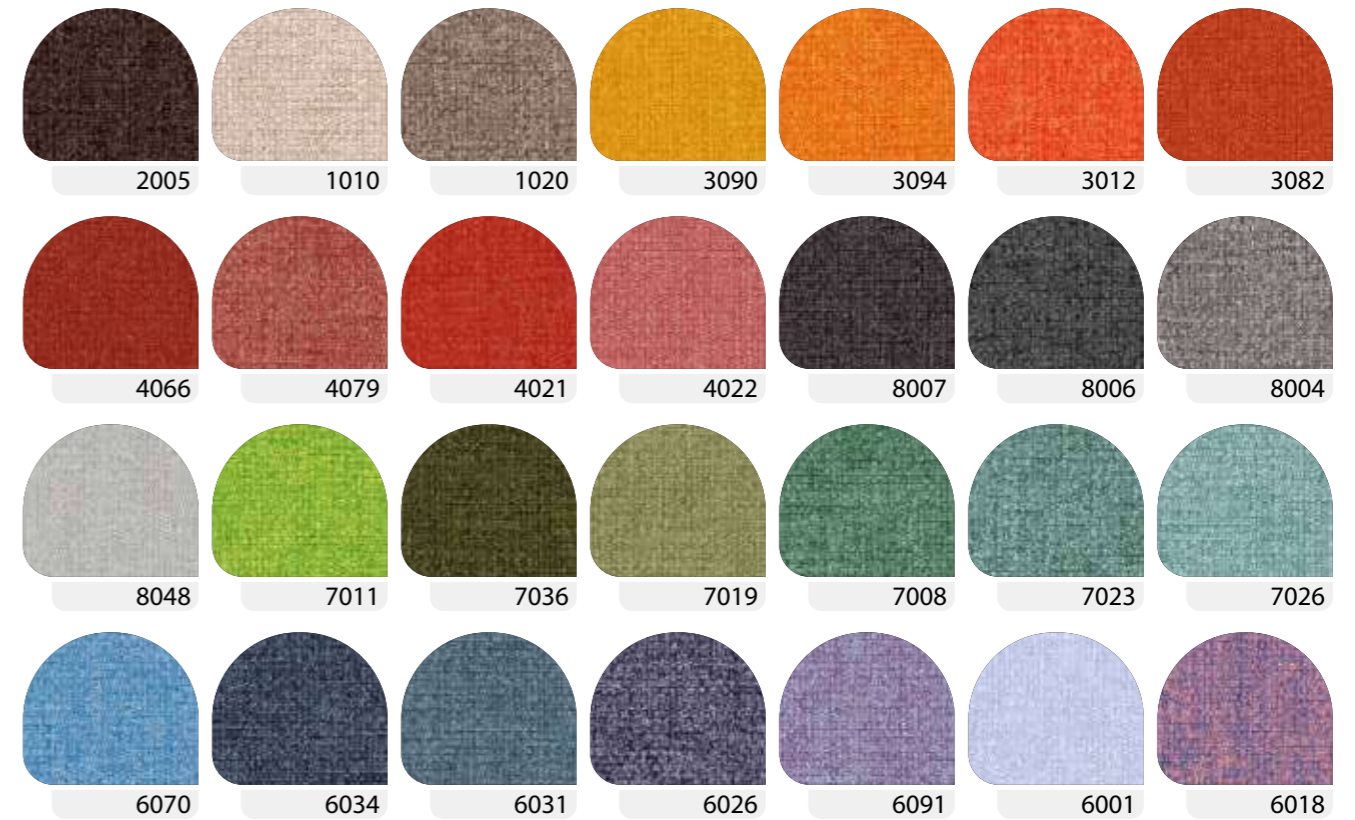

# serie 600 | categoria B

710 ± 5% g/m<sup>2</sup> / Martindale: 100.000 / Flextest: 100.000 / Xenotest: 6 / Flammability: ~~X~~  
90% Pvc / 10% Nylon backing

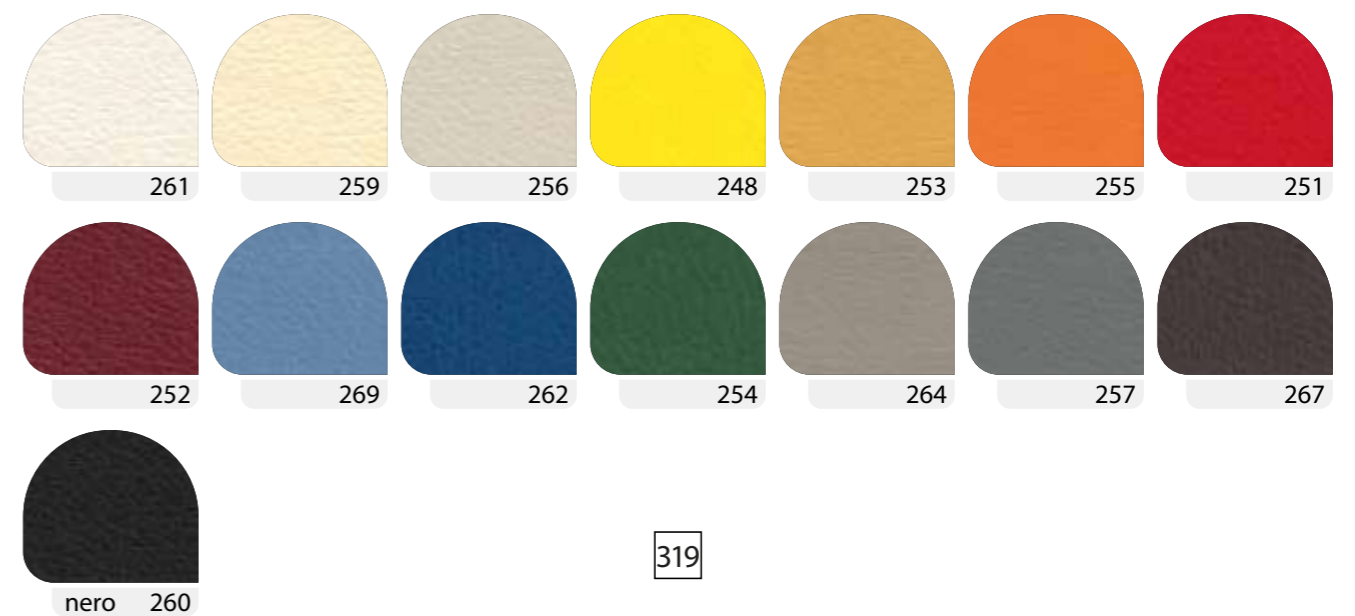

# celia | categoria D

375 ± 5% g/m<sup>2</sup> / Martindale: 55.000 / Pilling: 3-4 / Xenotest: 4-5 / Flammability:   
70% Recycled WO / 20% PL / 5% PA / 5% PC

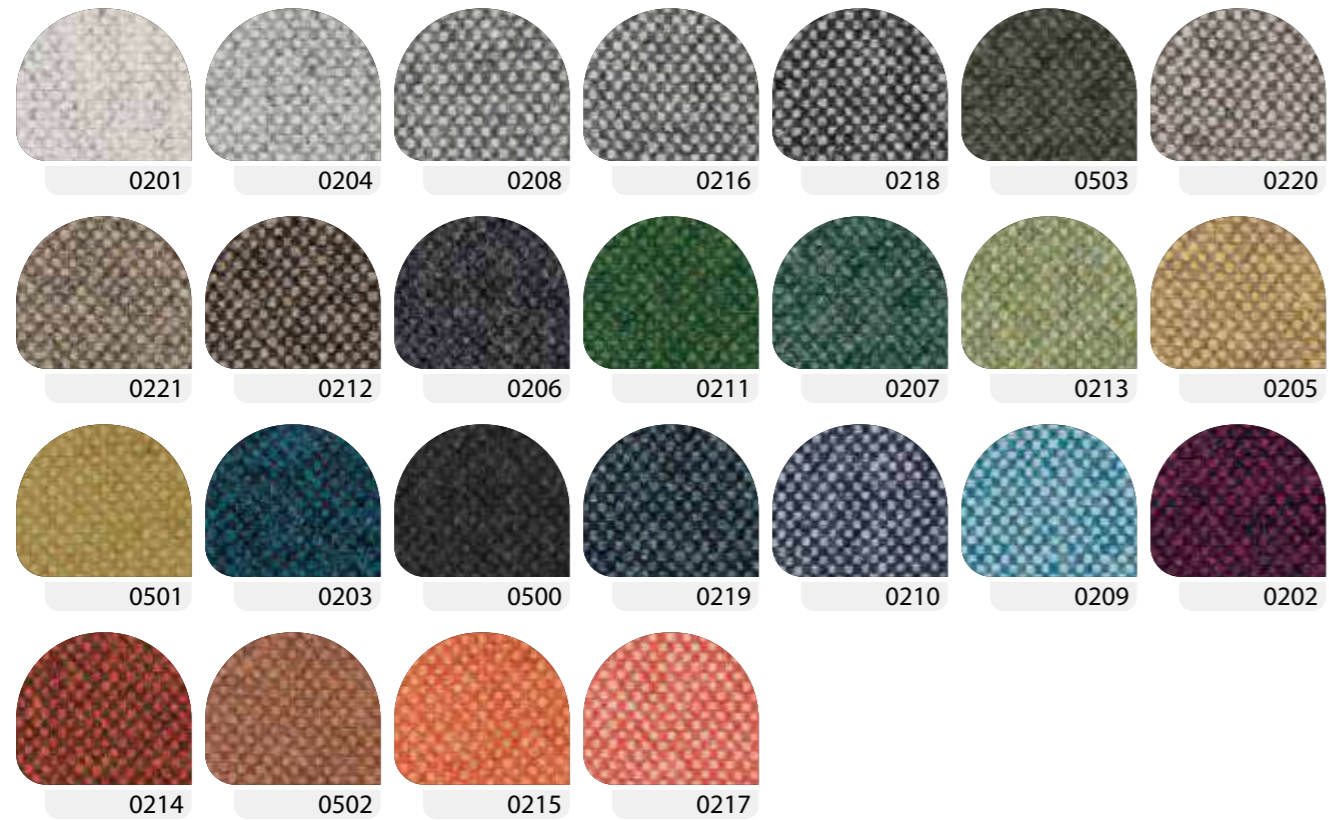

# vita | categoria D

850 ± 10% g/m<sup>2</sup> / Martindale: 100.000 / Xenotest: 6-7 / Flammability:   
98% Pvc / 2% PU. Substrate: 100% Cotton



# ecopelle plus | categoria D

**MOTTLED LOOK** / 700 ± 5% g/m<sup>2</sup> / Martindale: 100.000 / Flextest: 100.000 / Traction: 1100 / Xenotest: 6 / Flammability:   
60% Pvc coating / 40% Knitted polycotton backing

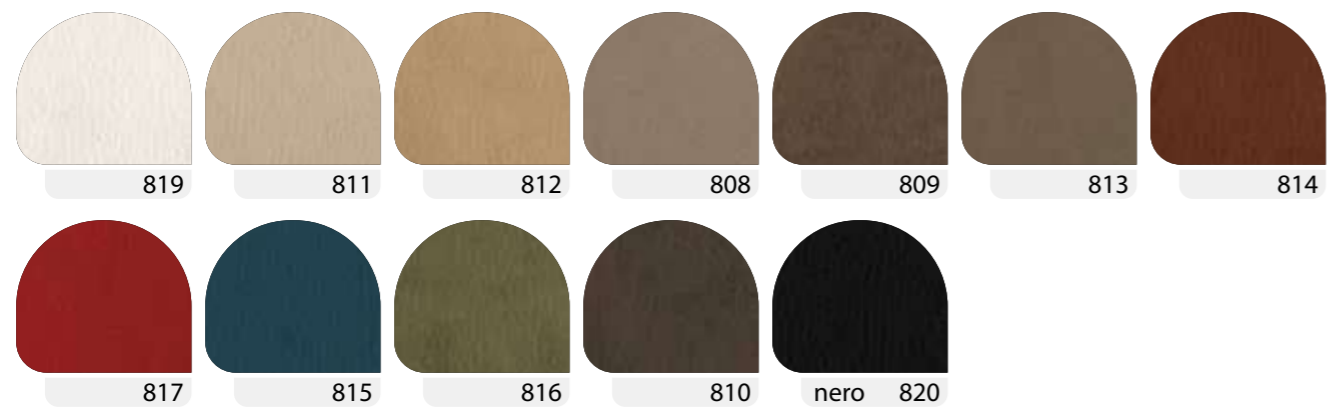

# xtreme | categoria D

310 ± 5% g/m<sup>2</sup> / Martindale: 100.000 / Pilling: 5 / Xenotest: 6 / Flammability:   
100% Post-consumer recycled polyester



# lucky | categoria D

400 ± 15 g/m<sup>2</sup> / Martindale: 200.000 / Xenotest: 4 / Flammability:   
100% High tenacity Polyester

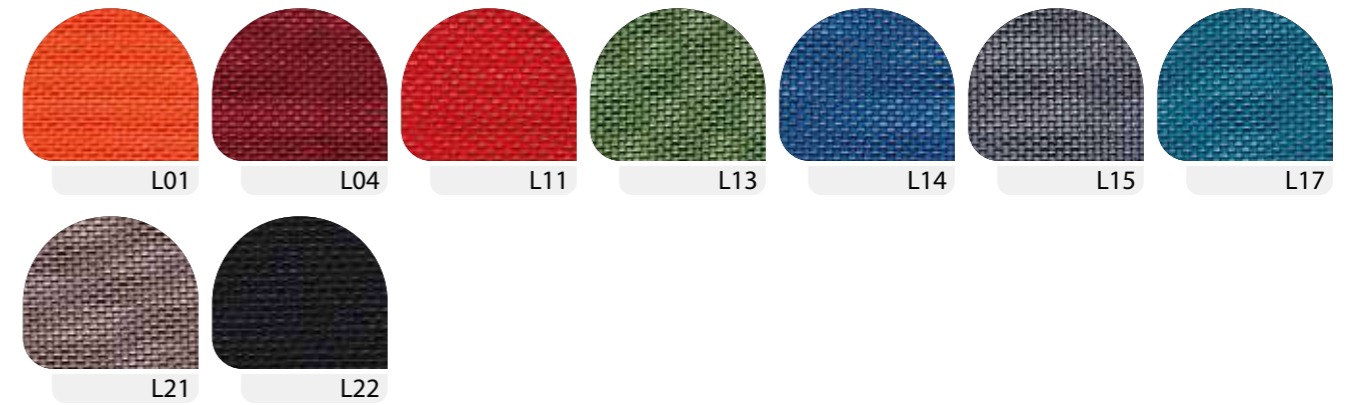

# ally | categoria E

420 g/m<sup>2</sup> / Martindale: 50.000 / Pilling: 5 / Xenotest: 5 / Flammability:   
95% Recycled PET / 5% Pes

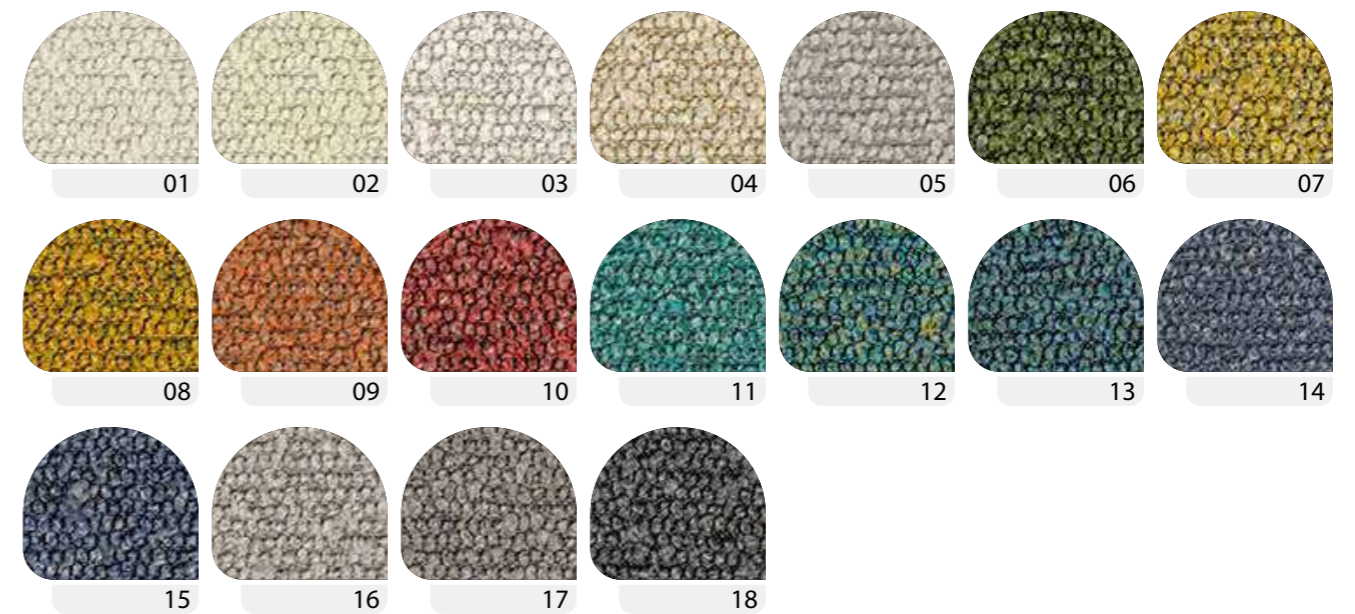

# fenice | categoria E

360 ± 5% g/m<sup>2</sup> / Martindale: 100.000 / Pilling: 5 / Xenotest: 6 / Flammability: ~~X~~  
75% Wool / 25% Polyammide



# main line flax | categoria E

437 ± 5% g/m<sup>2</sup> / Martindale: 50.000 / Rubbing: 3-4 / Xenotest: 4-5 / Flammability: ~~X~~  
75% Virgin Wool / 25% Flax



# ultra | categoria E

437 g/ml / Martindale: 500.000 / Pilling: 4 / Xenotest: 6-7 / Flammability: ~~X~~  
72% Pa / 16% Wo / 12% Cv

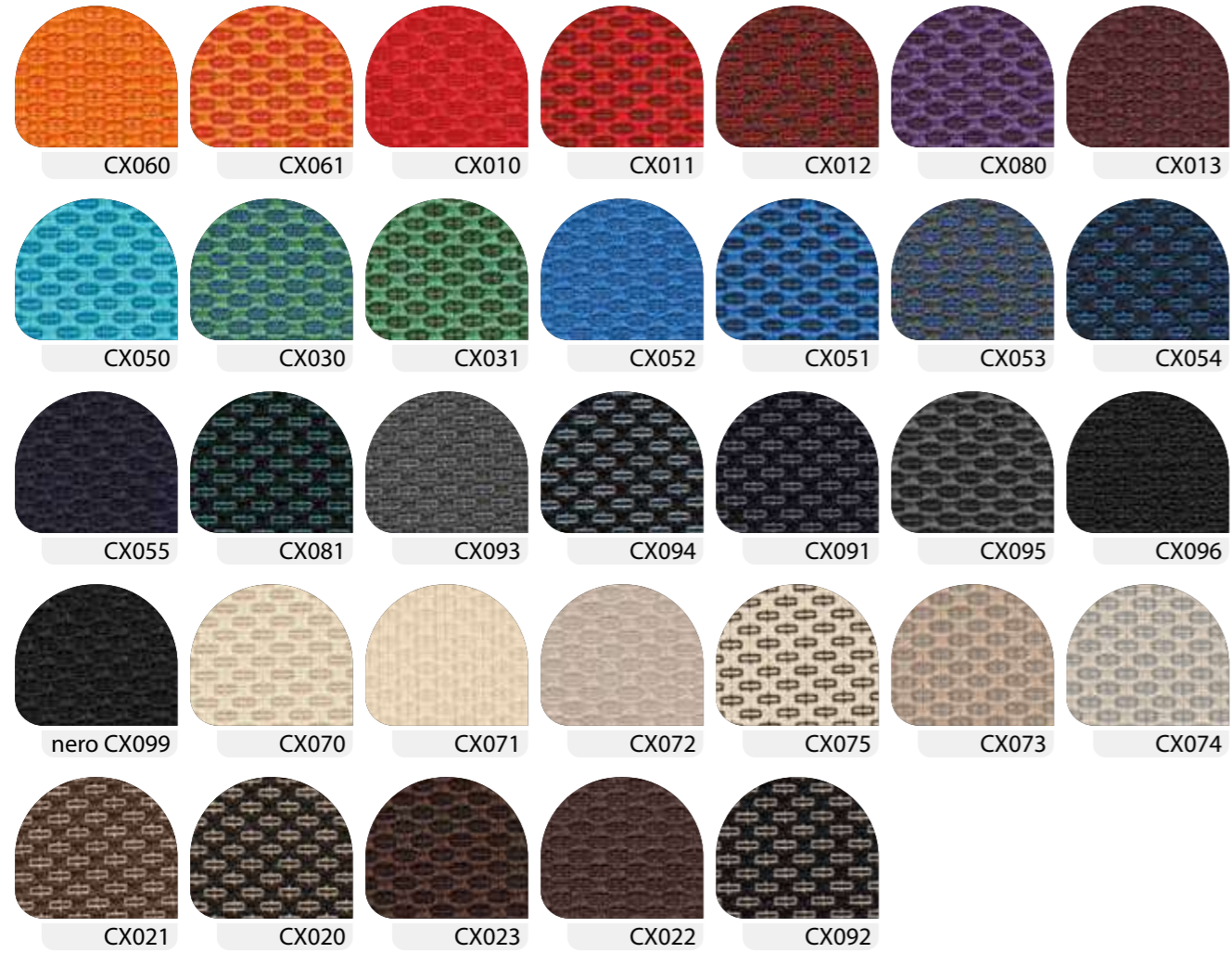

# blazer | categoria F

460 ± 5% g/m<sup>2</sup> / Martindale: 50.000 / Xenotest: 5 / Flammability: ~~X~~  
100% Virgin Wool



# sumi | categoria F

350 g/m<sup>2</sup> / Martindale: 200.000 / Rubbing: 4 / Xenotest: 4-6 / Flammability: ~~X~~  
90% Wool / 10% Polyamide



# pelle aliseo | categoria P

Thickness 0.9 - 1.1 mm / Xenotest: 4  
100% Leather



# pelle uruguay | categoria P1

Thickness 0.9 - 1.1 mm / Xenotest: 5  
100% Leather

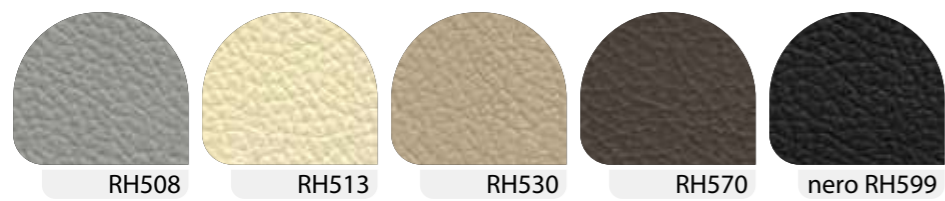

# rete | categoria RE e RT

350 g/m<sup>2</sup> / Martindale: 200.000 / Rubbing: 4 / Xenotest: 4-6 / Flammability:   
90% Wool / 10% Polyamide

star / active re / sprint re / wiki re / key ok



rush



cometa

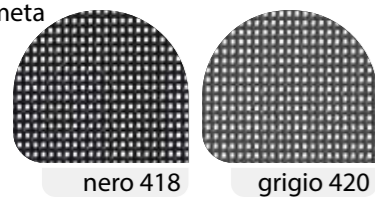

origami

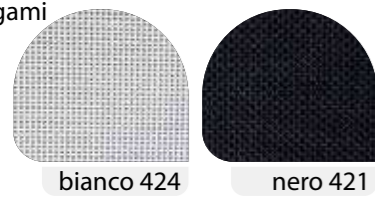

ilike re

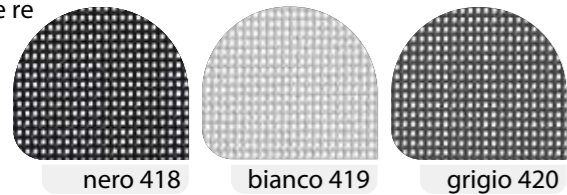

laila

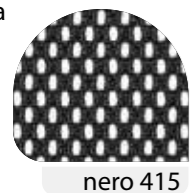

# plastica |

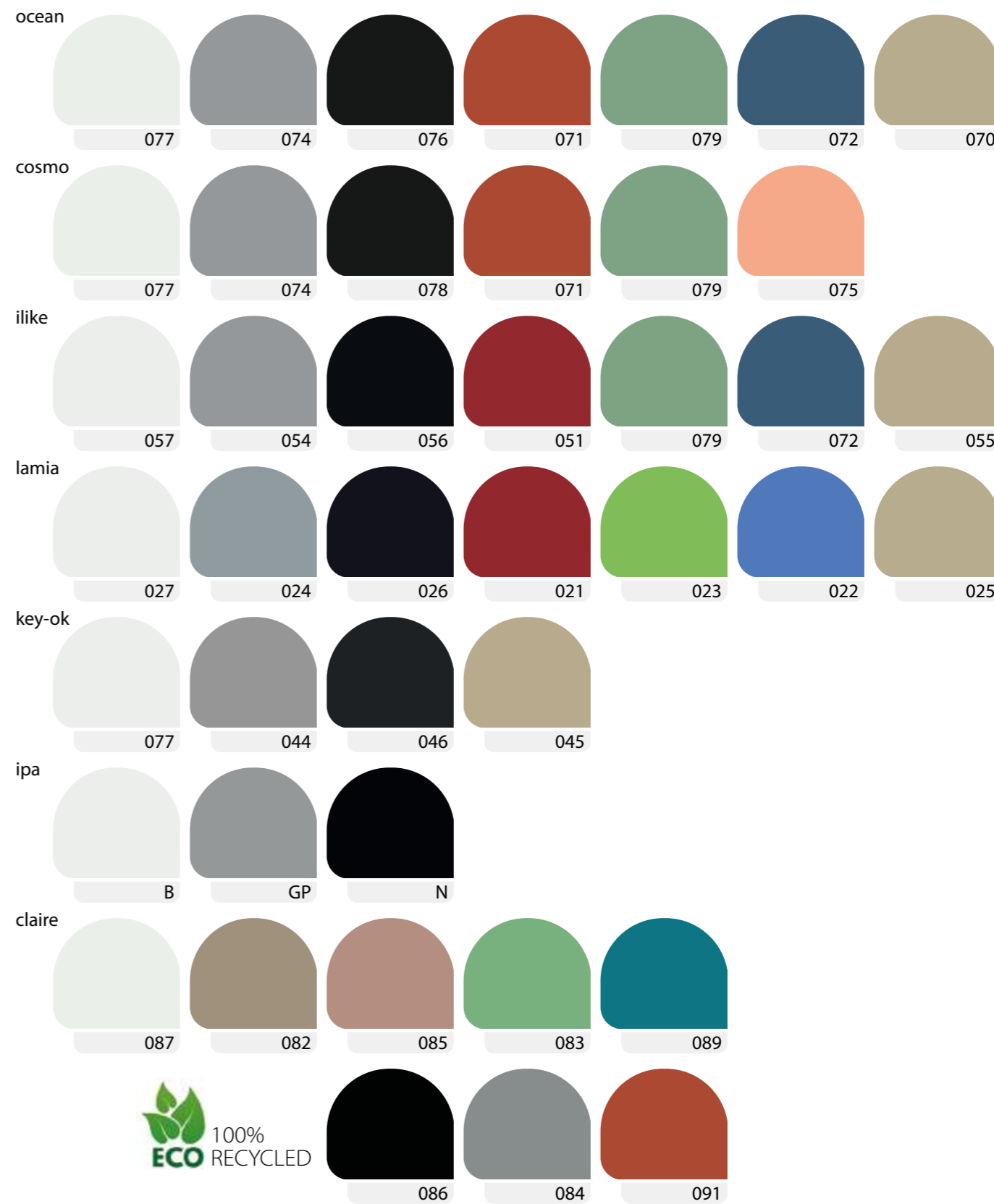

greta

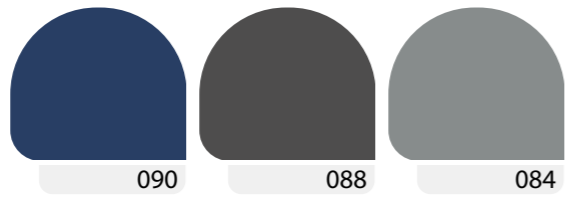
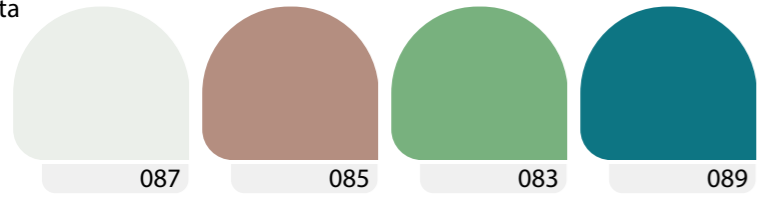

spot

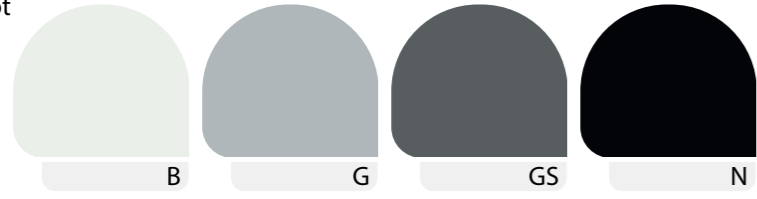

arcade

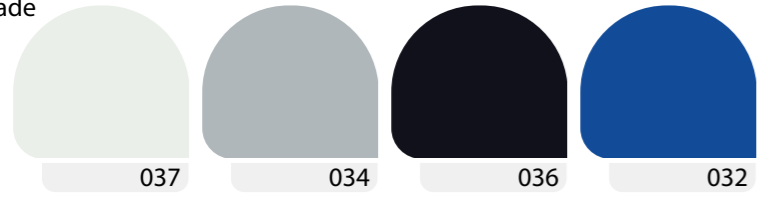

# legno |

Natural Beechwood (FG) and natural Oakwood (RV), transparent painted

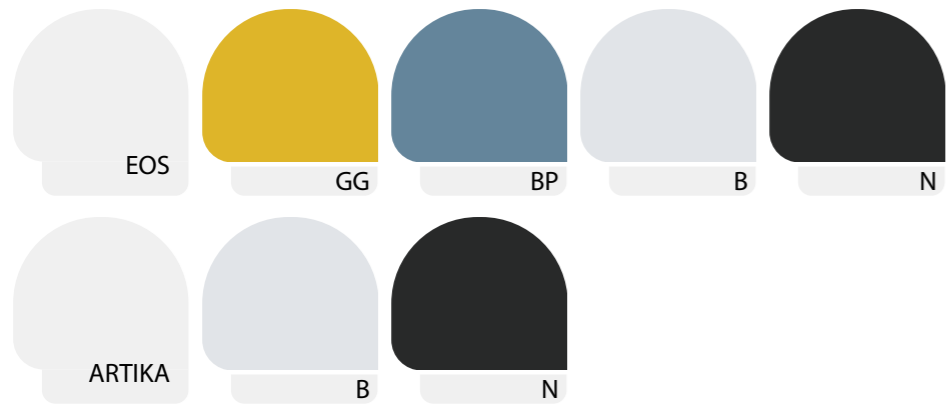

Textured lacquered paint





Leyform si riserva il diritto di apportare modifiche in qualsiasi momento al fine di migliorare la propria produzione.  
Leyform reserves the right to make at any time technical changes to its products aimed at improving it.  
Leyform se reserve le droit d'apporter à ses produits à chaque moment toutes modifications afin de l'améliorer.  
Leyform behält sich das Recht vor, jederzeit technische Änderungen an den Produkten vorzunehmen,  
um diese zu verbessern.

Leyform Srl

Via Pertini, 1  
31014 Colle Umberto  
Treviso - Italy  
Tel +39 0438 430 050  
Fax +39 0438 430 487  
www.leyform.com  
info@leyform.com

Layout, graphic design, images, postproduction, photo, text and art direction

Leyform Srl

Print  
April 2024



## **Leyform Srl**

Via Pertini, 1  
31014 Colle Umberto  
Treviso - Italy

Tel +39 0438 430050  
Fax +39 0438 430487

[www.leyform.com](http://www.leyform.com)  
[info@leyform.com](mailto:info@leyform.com)